

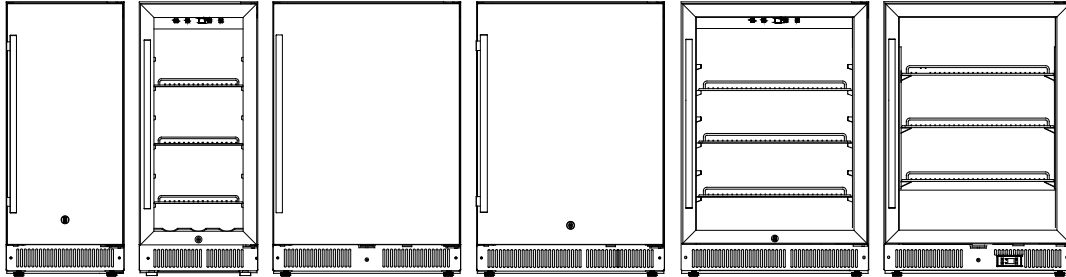

## Refrigerators, Beverage Centers, and Freezers (15", 21" & 24" Wide)

User Manual



### MODELS:

#### Refrigerators

AL54 | ALR15B | DBAR1526 | DBAROS1531 | DBAROS2428ASD | DBAROS2429  
SPR316OS | SPR618OSADA | SPR621OS | SPR624OS | SPR627OS

#### Beverage Centers

AL57G | DBGROS2467 | SCR1536BG | SCR2464 | SCR610BL | SCR611GLOS

#### Freezers

DBFZOS2458 | SCF475 | SPFF51OS

**BEFORE USE, PLEASE READ AND FOLLOW ALL SAFETY RULES AND OPERATING INSTRUCTIONS.**

**Models:**

**Serial Number:**

**Felix Storch, Inc.**  
An ISO 9001:2015 registered company  
770 Garrison Ave  
Bronx, New York 10474  
[www.summitappliance.com](http://www.summitappliance.com)

# TABLE OF CONTENTS

<b>Appliance Safety</b>	<b>3</b>
<b>Important Safeguards</b>	<b>3-5</b>
<b>Disposal</b>	<b>5</b>
<b>Electrical Connection</b>	<b>6</b>
<b>Location of Parts</b>	<b>7-9</b>
<b>Installation Instructions</b>	<b>10-13</b>
<i>Before Using your Appliance</i>	9
<i>Installation of your Appliance</i>	9-10
<i>Built-In Under-Counter Instructions</i>	11
<i>Reversing the Door Swing of your Appliance</i>	12
<i>Adjusting the Height of the Unit</i>	12
<i>Adjusting the Kick Plate</i>	13
<i>Installing the Stainless Steel Handle</i>	13
<b>Operating your Appliance</b>	<b>14-19</b>
<i>Control Panel</i>	14-17
<i>Sabbath Mode</i>	18
<i>Temperature Memory Function</i>	18
<i>Defrosting</i>	18
<i>Using the Freezer</i>	18
<i>Temperature Alarm/Door Alarm</i>	18
<i>Door Lock</i>	18
<i>Shelves</i>	19
<i>Door Racks</i>	19
<b>Care and Maintenance</b>	<b>20</b>
<i>Cleaning your Appliance</i>	20
<i>Power Failure</i>	20
<i>Vacations</i>	20
<i>Moving your Appliance</i>	20
<i>Energy-Saving Tips</i>	20
<b>Troubleshooting</b>	<b>21-22</b>
<b>Limited Warranty</b>	<b>24</b>

# APPLIANCE SAFETY

Your safety and the safety of others are very important.

We have provided many important safety messages in this manual and on your appliance. Always read and obey all safety messages.



This is the Safety Alert Symbol. The symbol alerts you to potential hazards that can kill or injure you and others. All safety messages will follow the Safety Alert Symbol and either the word DANGER or WARNING.



DANGER means that failure to heed this safety statement may result in severe personal injury or death.



WARNING means that failure to heed this safety statement may result in extensive product damage, serious personal injury, or death.

All safety messages will alert you about the potential hazard, tell you how to reduce the chance of injury, and let you know what can happen if the instructions are not followed.

---

## IMPORTANT SAFEGUARDS



Before the appliance is used, it must be properly positioned and installed as described in this manual, so read the manual carefully. To reduce the risk of fire, electrical shock or injury when using the appliance, follow basic precautions, including the following:



- Plug into a grounded 3-prong outlet, do not remove grounding prong, do not use an adapter, and do not use an extension cord.
- Replace all panels before operating.
- It is recommended that a separate circuit serving only your appliance be provided. Use receptacles that cannot be turned off by a switch or pull chain.
- **WARNING:** Never clean appliance parts with flammable fluids. These fumes can create a fire hazard or explosion. And do not store or use gasoline or other flammable vapors and liquids or explosive substances such as aerosol cans with a flammable propellant in this appliance or in the vicinity of this or any other appliance. The fumes can create a fire hazard or explosion.
- Do not connect or disconnect the electric plug when your hands are wet.
- Unplug the appliance or disconnect power before cleaning or servicing. Failure to do so can result in electrical shock or death.
- Do not attempt to repair or replace any part of your appliance unless it is specifically recommended in this manual. All other servicing should be referred to a qualified technician.



A3

Warning: Risk of Fire / Flammable Materials.



R600a

- This appliance is CFC- and HFC-free and contains small quantities of Isobutane (R600a) which is environmentally friendly, but flammable. It does not damage the ozone layer, nor does it increase the greenhouse effect. Care must be taken during transportation and setting up of the appliance that no parts of the cooling system are damaged. Leaking coolant can ignite and may damage the eyes.
- In the event of any damage:
  - Avoid open flames and anything which creates a spark,
  - Disconnect from the power supply,
  - Air the room in which the appliance is located for several minutes and
  - Contact the Service Department for advice.
- The more coolant there is in an appliance, the larger the room it should be installed in. In the event of a leakage, if the appliance is in a small room, there is the danger of combustible gases building up. For every ounce of coolant at least 325 cubic feet of room space is required. The amount of coolant in the appliance is stated on the data plate inside the appliance. It is hazardous for anyone other than an Authorized Service Person to carry out servicing or repairs to this appliance.
- Take serious care when handling, moving, and using the appliance to avoid either damaging the refrigerant tubing or increasing the risk of a leak.
- Replacing component parts and servicing shall be done by factory authorized service personnel, so as to minimize the risk of possible ignition due to incorrect parts or improper service.
- This appliance is not intended for use by persons (including children) with reduced physical, sensory, or mental capabilities, or lack of experience and knowledge, unless they have been given supervision or instruction concerning use of the appliance by a person responsible for their safety.
- Children should be supervised to ensure that they do not play with the appliance.



**FOLLOW WARNING CALLOUTS BELOW ONLY WHEN APPLICABLE TO YOUR MODEL**

- Use two or more people to move and install appliance. Failure to do so can result in back or other injury.
- **WARNING:** Keep ventilation openings, in the appliance enclosure or in the built-in structure, clear of obstruction.
- **WARNING:** Do not use mechanical devices or other means to accelerate the defrosting process or to clean, other than those recommended by the manufacturer.
- **WARNING:** The appliance shall be stored in a room without continuously operating ignition sources (for example: open flames, an operating gas appliance or an operating electric heater).
- **WARNING:** Do not pierce or burn. Do not damage the refrigerant circuit.
- **WARNING:** Be aware that refrigerants may not contain an odor.
- **WARNING:** Do not use electrical appliances inside the food storage compartments of the appliance, unless they are of the type recommended by the manufacturer.
- **WARNING:** To avoid a hazard due to the instability of the appliance, it must be fixed in accordance with the instructions.
- **WARNING:** Danger of injury from LED lamp. If the cover is defective: do not look directly into the illumination with optical lenses from close proximity. The eyes can be injured.
- **CAUTION:** Use this appliance only for its intended purpose. This equipment is intended for the storage and display of packaged products only.
- To ensure proper ventilation for your appliance, the front of the unit must be completely unobstructed. Choose a well-ventilated area with temperatures above 44°F (7°C) and below 90°F (32°C).
- The appliance should not be located next to ovens, grills, or other sources of high heat.
- The appliance must be installed with all electrical, water and drain connections in accordance with state and local codes. A standard electrical supply (115 V AC only, 60 Hz), properly grounded in accordance with the National Electrical Code and local codes and ordinances, is required.
- Do not kink or pinch the power supply cord of the appliance.
- The size of the fuse (or circuit breaker) should be 15 amperes.
- It is important that the appliance be leveled in order to work properly. You may need to make several adjustments to level it.

- All installations must be in accordance with local plumbing code requirements.
- Make certain that the pipes are not pinched, kinked, or damaged during installation.
- Check for leaks after connection.
- Never allow children to operate, play with or crawl inside the appliance.
- Do not use solvent-based cleaning agents or abrasives on the interior. These cleaners may damage or discolor the interior.
- Use this appliance only for its intended purpose as described in this *Instruction Manual*.
- Keep fingers out of the “pinch point” areas. Clearances between the door and cabinet are necessarily small. Be careful closing the door when children are in the area.

## - SAVE THESE INSTRUCTIONS -

### DISPOSAL

Dispose of your appliance packaging properly. Ensure that any plastic wrappings, bags, etc., are disposed of safely and kept out of the reach of babies and young children. **Danger of suffocation!**

Refrigeration equipment must be properly disposed of in a professional and appropriate way, in accordance with the current local regulations and laws which protect the environment. This applies to your old appliance and to your new unit once it has reached the end of its service life.

**WARNING:** Please ensure that old, worn appliances are rendered unusable before disposal by removing the doors, removing the plug, cutting the network cable, and removing or destroying any snap fastenings or bolts. Leave shelving in place. You will thus prevent children from locking themselves in the appliance during play (risk of suffocation) or endangering their lives in any other way. DO NOT dispose of the appliance in landfill as the insulation (Cyclopentane) and refrigerant gas (R600a) contained in these appliances are flammable.

#### Disposal instructions:

- The appliance must not be disposed of in the dustbin or with normal household rubbish.
- The coolant circuit, particularly the heat exchanger at the back/bottom of the unit, must not be damaged.
- The appliance is not to be handled as normal household waste but is to be taken to a recycling collection point for electrical and electronic goods. By correctly disposing of this product, you are contributing to the protection of the environment and to the health of your fellow human beings. Improper disposal endangers health and the environment. Further information about the recycling of the product may be obtained from your town hall, refuse collection department or the store where you purchased the product.



#### ***Risk of child entrapment!***

Child entrapment and suffocation are not problems of the past. Junked or abandoned appliances are still dangerous, even if they will “just sit for a few days.”

*Before discarding your old refrigerator:*

- *Take off the doors*
- *Leave the shelves in place so that children may not easily climb inside.*

## Electrical Connection



Improper use of the grounded plug can result in the risk of electrical shock. If the power cord is damaged, have it replaced by a qualified electrician or an authorized service center.

This appliance should be properly grounded for your safety. The power cord of this appliance is equipped with a three-prong plug which mates with standard three-prong wall outlets to minimize the possibility of electrical shock.

Do not under any circumstances cut or remove the third (ground) prong from the power cord supplied. For personal safety, this appliance must be properly grounded. Any questions concerning power and/or grounding should be directed toward a certified electrician or an authorized service center.

This appliance requires a standard 115/120 Volt AC ~ 60Hz three-prong grounded electrical outlet. Have the wall outlet and circuit checked by a qualified electrician to make sure the outlet is properly grounded. When a standard 2-prong wall outlet is encountered, it is your responsibility and obligation to have it replaced with a properly grounded 3-prong wall outlet.

To prevent accidental injury, the cord should be secured behind the appliance and not left exposed or dangling.

The appliance should always be plugged into its own individual electrical outlet which has a voltage rating that matches the rating label on the appliance. This provides the best performance and also prevents overloading house wiring circuits that could cause a fire hazard from overheating. Never unplug the appliance by pulling on the power cord. Always grip the plug firmly and pull straight out from the receptacle. Repair or replace immediately all power cords that have become frayed or otherwise damaged. Do not use a cord that shows cracks or abrasion damage along its length or at either end. When moving the appliance, be careful not to damage the power cord.

### **Extension Cord**

Because of potential safety hazards under certain conditions, it is strongly recommended that you do not use an extension cord with this appliance. However, if you must use an extension cord, it is absolutely necessary that it be a UL/CUL-Listed, 3-wire grounding type appliance extension cord having a grounding type plug and outlet and that the electrical rating of the cord be 115 volts and at least 10 amperes.

# LOCATION OF PARTS

**Refrigerators:**

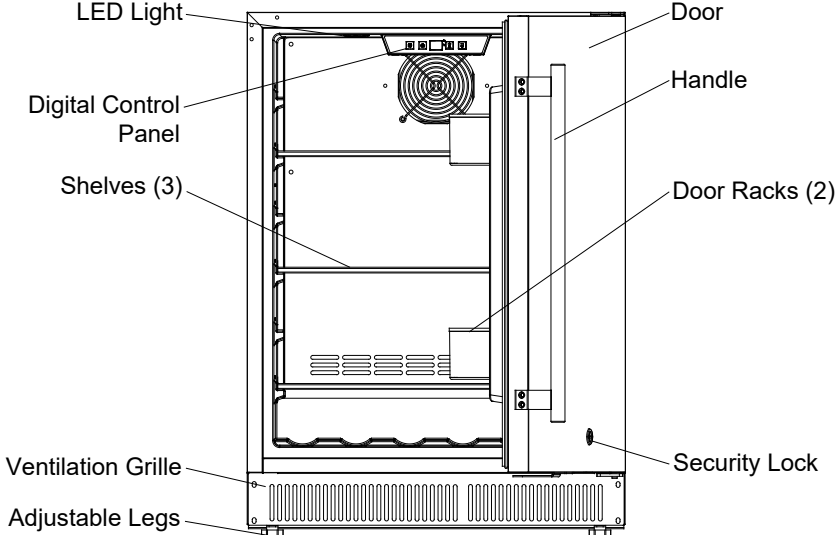

---

**ALR5B | SPR316OS | AL54 | SPR621OS | SPR624OS | SPR627OS**  
**DBAR1526 | DBAROS1531**

---

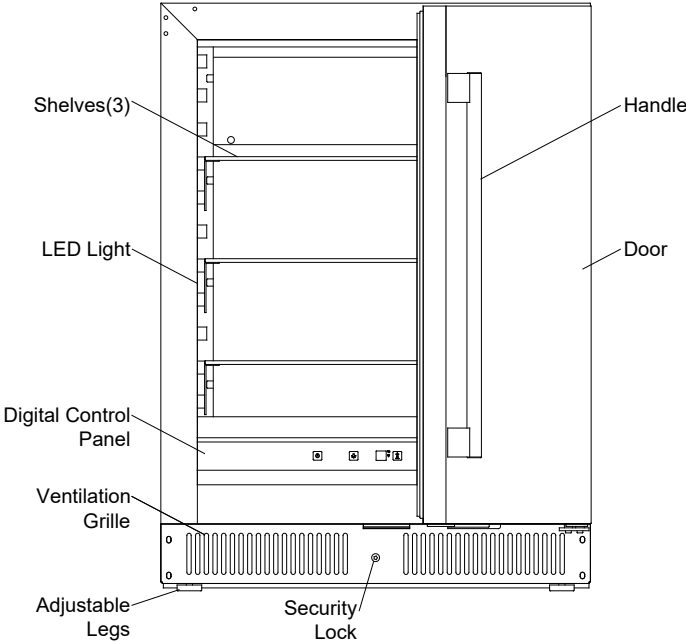



---

**SPR618OSADA | DBAROS2428ASD**

---

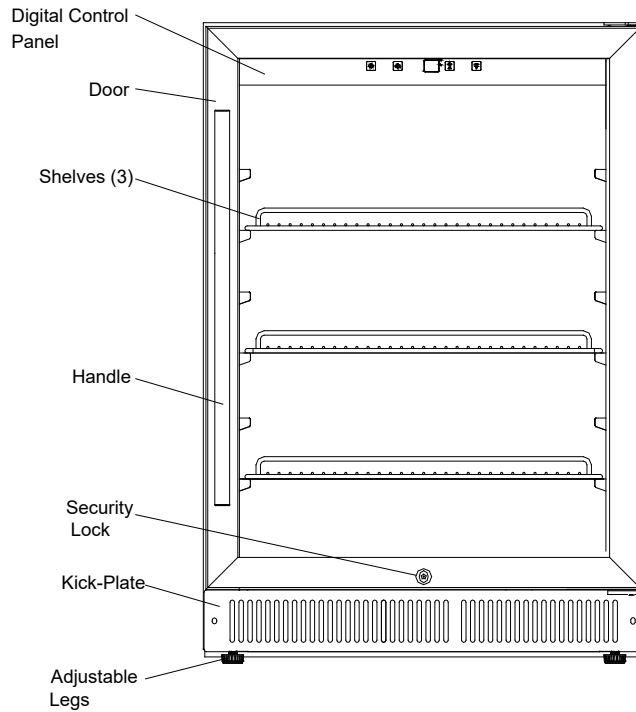
## Beverage Centers:



SCR1536BG | AL57G | SCR2464 | SCR611GLOS | DBGROS2467

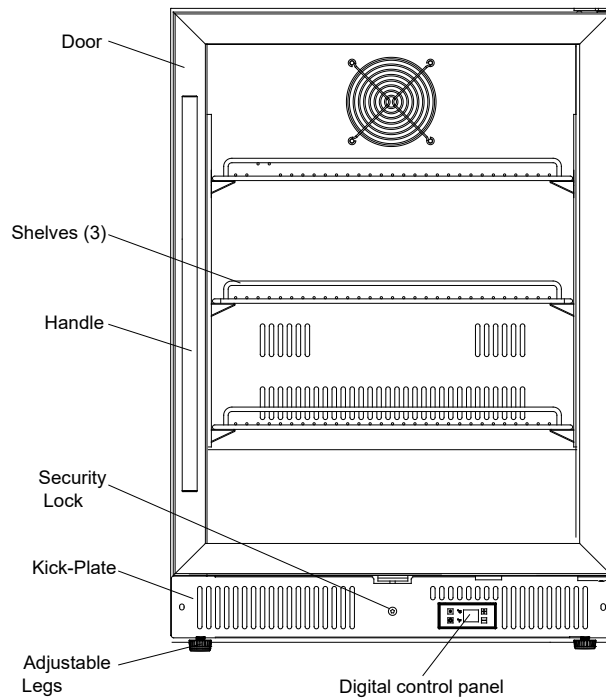

SCR610BL

Features are subject to change by model\*\*

**Freezers:**

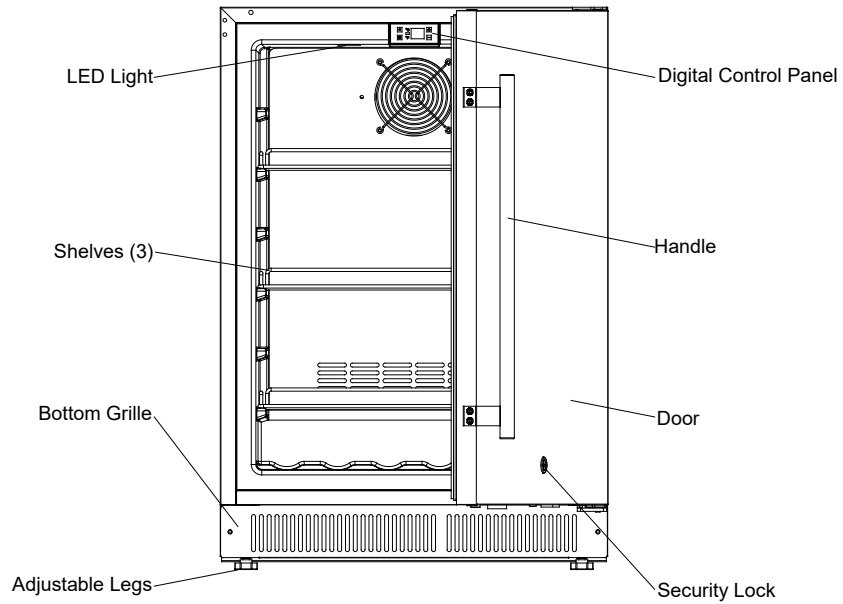

---

**SPFF510S | DBFZOS2458**

---

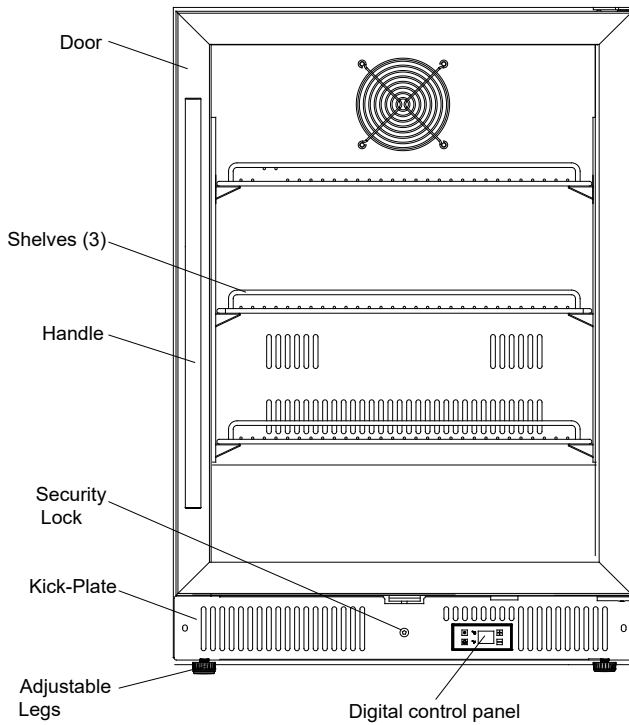

---

**SCF475**

---

**Features are subject to change by model\*\***

# INSTALLATION INSTRUCTIONS

## Before Using Your Appliance

- Remove the exterior and interior packing.

**CAUTION:** After unpacking you **MUST** allow this appliance to stand upright for at least 2 hours to allow the lubricant and refrigerant to drain back into the compressor and stabilize. Failure to do so may adversely affect performance and the lifetime of this unit.

- Clean the interior surface with lukewarm water using a soft cloth.
- Install the handle on the door. (See Installing the Stainless Steel Handle.)

## Installation of your Appliance

**CAUTION:** This appliance is not designed for the storage of medicine, or other medical products.

- The appliance is designed for built-in, recessed, or freestanding installation.
- For models **SPR316OS, DBAROS1531, SPR621OS, SPR624OS, SPR627OS, DBAROS2429, SPR618OSADA, DBAROS2428ASD, SCR611GLOS, DBGROS2467, SPFF51OS, and DBFZOS2458**, installation is suitable for both indoor and outdoor use.
- **All other models are intended for indoor use only.**

**NOTE:** Do not store or install the appliance outdoors for indoor use only models.

- Place your appliance on a floor that is strong enough to support it when it is fully loaded. To level the unit, adjust the front leveling legs.
- For freestanding installation, **5"** (127mm) of space at the back and sides of the unit and **4"** (102mm) at the top are suggested, this allows the proper air circulation to cool the compressor and condenser for energy saving. Even for built-in installation, it is better to keep at least **¼"** (6.4mm) of space on each side, **2"** (51mm) at the back, and **⅛"** (3mm) at the top to ensure proper service access and ventilation. And the air vent at the front of the appliance must never be covered or blocked in any way.

**CAUTION:** Make sure that the socket and ON/OFF switch are easily accessible after the appliance has been installed.

- Avoid locating the unit in moist areas.
- Plug the appliance into an exclusive, properly grounded wall outlet. Do not under any circumstances cut or remove the third (grounding) prong from the power cord. Any questions concerning power and/or grounding should be directed toward a certified electrician or an authorized service center.
- Plug the appliance into an exclusive, properly grounded wall outlet.

**NOTE:** It is recommended that you do not install the appliance near an oven, radiator, or another heating source. Direct sunlight may affect the acrylic coating and heat sources may increase electrical consumption. Do not install in a location where the temperature will fall below **60°F** (16°C) for indoor use only models. For best performance, do not install the appliance behind a cabinet door or block the base grille.

## Built-In Under-Counter Instructions

Make sure your installation does not block the front ventilation grille. The unit is designed to fit under worktops, using the height-adjustable ventilation grille to ensure that the feet are concealed from the front view.

If the unit is to be installed in an area with a kitchen plinth, make sure that the ventilation gaps in the plinth are at least 300cm<sup>2</sup> (46.5in<sup>2</sup>) and remove the ventilation grilles, so that warm air can disperse without interruption. Otherwise, the appliance must work harder, increasing electricity consumption.

**NOTE:** When pushing the appliance into the niche, make sure that the main cable does not get trapped.

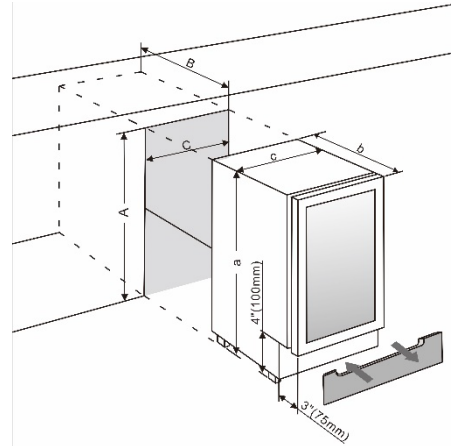

Model No.	a (Inch/mm)	b (Inch/mm)	c (Inch/mm)	A (Inch/mm)	B (Inch/mm)	C (Inch/mm)
<b>ALR15B</b>	32" / 813	22 <sup>3</sup> / <sub>4</sub> " / 575	14 <sup>3</sup> / <sub>4</sub> " / 375	32 <sup>1</sup> / <sub>8</sub> " / 816	22 <sup>3</sup> / <sub>4</sub> " / 575	15" / 380
<b>SCR1536BG</b>	34" / 864	22 <sup>3</sup> / <sub>4</sub> " / 575	14 <sup>3</sup> / <sub>4</sub> " / 375	34 <sup>1</sup> / <sub>8</sub> " / 866	22 <sup>3</sup> / <sub>4</sub> " / 575	15" / 380
<b>SPR621OS</b>	32" / 813	22" / 560	20 <sup>3</sup> / <sub>4</sub> " / 527	32 <sup>1</sup> / <sub>8</sub> " / 816	22" / 560	21" / 533
<b>SPR624OS</b>	32" / 813	22" / 560	23 <sup>1</sup> / <sub>2</sub> " / 595	32 <sup>1</sup> / <sub>8</sub> " / 816	22" / 560	23 <sup>5</sup> / <sub>8</sub> " / 600
<b>AL57G</b>	32" / 813	22 <sup>3</sup> / <sub>4</sub> " / 575	23 <sup>1</sup> / <sub>2</sub> " / 595	32 <sup>1</sup> / <sub>8</sub> " / 816	22 <sup>3</sup> / <sub>4</sub> " / 575	23 <sup>5</sup> / <sub>8</sub> " / 600
<b>SCR2464</b>	34" / 864	23 <sup>1</sup> / <sub>2</sub> " / 596	23 <sup>1</sup> / <sub>2</sub> " / 595	34 <sup>1</sup> / <sub>8</sub> " / 866	23 <sup>5</sup> / <sub>8</sub> " / 600	23 <sup>5</sup> / <sub>8</sub> " / 600
<b>SPR618OSADA</b>	32" / 813	18" / 455	23 <sup>1</sup> / <sub>2</sub> " / 595	32 <sup>1</sup> / <sub>8</sub> " / 816	18" / 455	23 <sup>5</sup> / <sub>8</sub> " / 600

### NOTE:

1. **Same as SCR1536BG**
  - SPR316OS • DBAROS1531
2. **Same as AL57G**
  - AL54
3. **Same as SCR2464**
  - SPR627OS • DBAROS2429 • SCR610BL • SCR611GLOS
  - SPFF51OS • DBFZOS2458 • DBGROS2467
4. **Same as SPR618OSADA**
  - DBAROS2428ASD

## Reversing the Door Swing of Your Appliance

This unit has the capability of the door opening from either the left or right side. The unit is delivered to you with the door opening from the left side. Should you desire to reverse the opening direction, please follow the reversal instructions shown below.

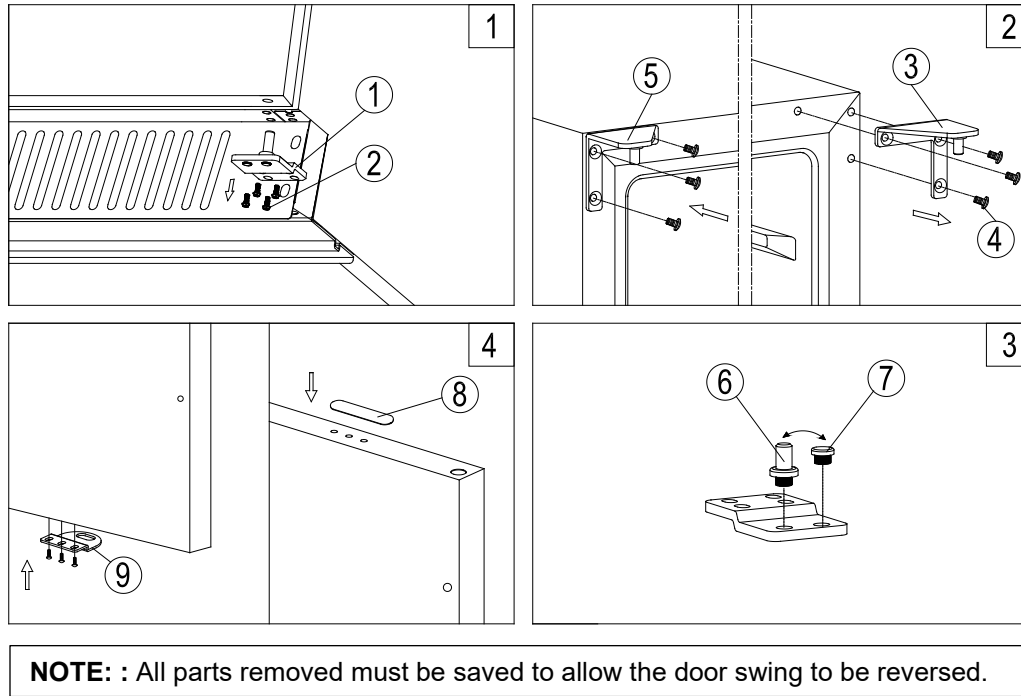

1. Remove the bottom hinge (1) by unscrewing the four lock screws (2). Hold the door firmly after removing the screws to prevent it from falling. (**Fig. 1**)
2. Gently pull the door downward to detach it from the right top hinge, then place it on a padded surface to avoid damage. Remove the right top hinge (3). (**Figs. 2**)
3. Unscrew the pin (6) and door stopper (7) on the bottom hinge and swap their positions. (**Fig. 3**)
4. Remove the cover caps on the left side of the cabinet and use them to cover the screw holes on the right side.
5. Screw the alternative left top hinge (5), provided with the accessories, on the left side of the cabinet. (**Fig. 2**)
6. For models with a security lock on the ventilation grille, unscrew the hole cover (8) and latch lock (9), then swap their positions by reinstalling them on the opposite sides of the door. (**Fig. 4**)
7. For models with security lock on the ventilation grille, rotate the door 180°, insert it into the newly installed top hinge, and hold it firmly in place.
8. Attach the bottom hinge assembly to the designated position on the left side. Once the door is properly aligned and level, tighten the hinge screws to secure it.

## Adjusting the Height of the Unit

The height of the ADA refrigerators can be increased by up to 3" by turning the adjustable legs. Once the desired height has been achieved, the gap between the kick-plate and the floor can be covered by lowering a hidden section of the kick-plate. See the next section for instructions.

## Adjusting the Kick-Plate (only for ADA models)

The pre-fitted kick-plate of the appliance includes an adjustable kick-plate section that is initially seated behind the upper section. In order to adjust the kick-plate height, follow the instructions below:

1. Remove the screws (1) from both the top left- and top right-hand sides of the kick-plate.
2. Loosen or remove the screws (2) from both the bottom left and bottom right-hand sides of the kick-plate. Failure to loosen the bottom screws sufficiently may cause damage to the lower trim when adjusting it.
3. Carefully guide the lower trim down until the desired height is achieved.
4. Reinsert screws and tighten them.

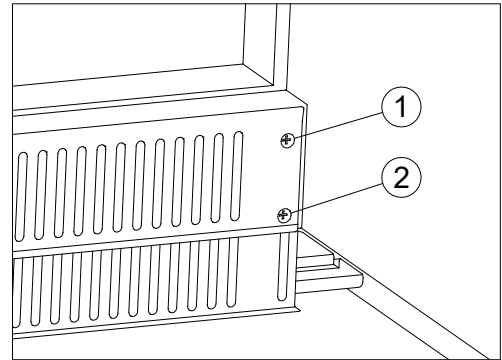

## Installing a Stainless Steel Handle

This appliance includes a stainless steel handle that is not required to operate the unit. To install the handle, follow the instructions below:

### For models:

SCR1536BG | AL57G | SCR2464 | SCR611GLOS  
DBGROS2467 | SPR618OSADA | DBAROS2428ASD  
SCR610BL | SCF475 | SPR621OS | SPR624OS

Place the handle (1) over the mounting stub (3) of the door and using the supplied Allen key, tighten the securing grub screws (2) to affix the handle.

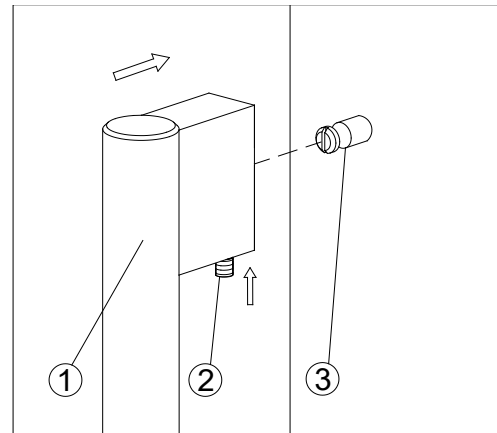

### For models:

ALR5B | SPR316OS | AL54 | SPR627OS | DBAR1526  
DBAROS1531 | SPFF51OS | DBFZOS2458

1. Use a screwdriver to remove the screws (1) on the side of the door where the handle is to be installed.
2. Align the handle (2) with the screws (1) removed in step # 1. Tighten the screws using a Phillips head screwdriver until the handle is both flush and secured tightly against the door side (3). (DO NOT over-tighten as this will cause damage to the stainless steel door surface.)

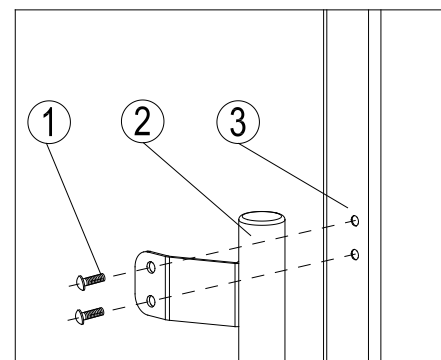

# OPERATING YOUR APPLIANCE

It is recommended you install the appliance in a place where the ambient temperature is between **44° and 90°F** (7° to 32°C). If the ambient temperature is above or below the recommended temperatures, the performance of the unit may be affected. For example, placing your unit in extreme cold or hot conditions may cause interior temperatures to fluctuate. The operating temperature range may not be reached.

## Control Panel



### ON/OFF Power

To turn the appliance **OFF**, press and hold the  key for 5 seconds.

To turn the appliance **ON**, press and hold the  key for 1 seconds.

**NOTE:** Pressing this key once will switch off the audible alarm when the alarm is on.

### Light

To turn the interior light **ON/OFF**, press and hold the  key for 5 seconds. The interior light indicator at the bottom right of the display will light up or go out to confirm the selection.

The interior light makes it easy to view your items. Press and hold the **LIGHT** symbol for 5 seconds to toggle between 2 modes of operation for the internal lights, Functional Mode (default) and Showcase Mode.

- **Functional Mode (default):** The light will turn on when the door is open.
- **Showcase Mode:** The light will remain on if the door is closed.

### UP

Used to increase (warm) the set temperature by 1°C/1°F.

### DOWN

Used to decrease (cool) the set temperature by 1°C/1°F.

### Setting the Temperature Control

- Set the temperature by pressing the **UP** and **DOWN** keys. Pressing either key for the first time, the LED readout will display the last temperature setting. (The temperature is preset to **38°F / 3°C**).
- To set the temperature, press the **UP** key to increase by 1°F / 1°C with each press. Press the **DOWN** key to decrease by 1°F / 1°C with each press.
- The range of the temperature control is from **36°F to 43°F** (2°C to 6°C).
- To view the set temperature at any time, press the **UP** or **DOWN** key. The set temperature will flash in the display window for 5 seconds. After 5 seconds, the temperature inside the unit will reappear on the display window.

### Settings Mode

Certain settings can only be selected in settings mode.

Press and hold the **UP** key for 5 seconds to enter or exit the Settings Mode. The appliance will exit Settings Mode automatically after one minute of inactivity.

### °F/°C Selection

1. Press and hold the **UP** key for 5 seconds to enter Settings Mode.
2. Use the **UP** and **DOWN** keys to select the temperature display setting in Fahrenheit or Celsius.
3. Press and hold the **UP** key for 5 seconds to confirm the selection.

### Display Brightness

1. Press and hold the **UP** key for 5 seconds to enter Settings Mode and then press the **POWER** key once.
2. Use the **UP** and **DOWN** keys to select the brightness of the display when the door is close. When the door is open, the display brightness returns to its normal level.
  - **d0**: off
  - **d1**: dimmest setting (default)
  - **d2**: medium setting
  - **d3**: brightest setting
3. Press and hold the **UP** key for 5 seconds to confirm the selection.

### Interior Lighting Brightness

1. Press and hold the **UP** key for 5 seconds to enter Settings Mode and then press the **POWER** key two (2) times.
2. Use the **UP** and **DOWN** keys to select the brightness of the interior lighting when the door is close. When the door is open, the interior lighting returns to its normal level.

- **L0**: off when the door is close or open
- **L1**: dimmest setting
- **L2**: medium setting
- **L3**: brightest setting (default)

3. Press and hold the **UP** key for 5 seconds to confirm the selection.

### Fan Mode

1. Press and hold the **UP** key for 5 seconds to enter Settings Mode and then press the **POWER** key three (3) times.
2. Use the **UP** and **DOWN** keys to select the fan mode.
  - **F0**: Silent Mode - Energy saving mode (default)
  - **F1**: DynaClima Mode - half time
  - **F2**: DynaClima Mode - full time
3. Press and hold the **UP** key for 5 seconds to confirm the selection.

### Audible Tones

1. Press and hold the **UP** key for 5 seconds to enter Settings Mode and then touch the **POWER** key four (4) times.
2. Use the **UP** and **DOWN** keys to select the audible tones.
  - **S0**: sensor tone ON, alarm tone OFF
  - **S1**: sensor tone ON, alarm tone ON (default)
  - **S2**: sensor tone OFF, alarm tone OFF
  - **S3**: sensor tone OFF, alarm tone ON
3. Touch and hold the **UP** key for 5 seconds to confirm the selection.

## Control Panel (for model SCR610BL)



### ON/OFF Power

To turn the appliance **OFF**, press and hold the  key for 5 seconds.

To turn the appliance **ON**, press and hold the  key for 1 seconds.

**NOTE:** Pressing this key once can switch off the audible alarm when the alarm is on.

### Up

Used to increase (warm) the set temperature by 1°C/1°F.

*To switch on the Silent Mode:* Press and hold the **UP** key for 5 seconds. Three beeps will confirm the selection.

### Down

Used to decrease (cool) the set temperature by 1°C/1°F.

*To switch on the Dynamic Cooling Mode:* Press and hold the **DOWN** key for about 5 seconds. Five beeps will confirm the selection.

### Light

The interior light makes it easy to view your items. Pressing the **LIGHT** key toggles between 2 modes of operation for the internal lights,

Functional Mode (default) and Showcase Mode.

- **Functional Mode (default):** The light will turn on when the door is open.
- **Showcase Mode:** The light will remain on if the door is closed.

### °F / °C Selector

To toggle the temperature display between Fahrenheit (°F) and Celsius (°C), press and hold the **LIGHT** key for 5 seconds.

### Setting the Temperature Control

- Set the temperature by pressing the **UP** and **DOWN** keys. Pressing either key for the first time, the LED readout will display the last temperature setting. (The temperature is preset to **38°F / 3°C**).
- To set the temperature, press the **UP** key to increase by 1°F / 1°C with each press. Press the **DOWN** key to decrease by 1°F / 1°C with each press.
- The range of the temperature control is from **36°F to 43°F** (2°C to 6°C).
- To view the set temperature at any time, press the **UP** or **DOWN** key. The set temperature will flash in the display window for 5 seconds. After 5 seconds, the temperature inside the unit will reappear on the display window.

## Control Panel (for freezers)

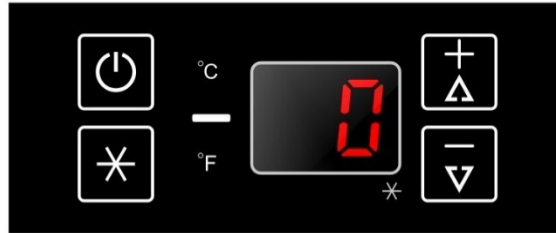

### **ON/OFF Power**

To power the appliance **ON/OFF**:

**ON:** Press and hold the  key for 1 second until the display lights up.

**OFF:** Press and hold the  key for 5 seconds until the display goes off.

**NOTE:** Pressing this key once can switch off the audible alarm when the alarm is on.

### **SuperFreeze**

The SuperFreeze function quickly freezes fresh food by overriding the thermostat control, allowing the compressor to run continuously. It is not necessary to adjust the thermostat when using this function.

When activated, the SuperFreeze indicator (light at the bottom right of the display) will light up. Press the SuperFreeze key again to cancel; the indicator will turn off. SuperFreeze turns off automatically after 8 hours.

### **UP**

Used to increase (warm) the set temperature by 1°C/1°F.

### **DOWN**

Used to decrease (cool) the set temperature by 1°C/1°F.

### **°F/°C Selector**

Select the temperature display setting in Fahrenheit or Celsius degree. To change the temperature from Fahrenheit to Celsius or from Celsius to Fahrenheit, press and hold the **SUPERFREEZE** key for 5 seconds.

### **Setting the Temperature Control**

- Set the temperature by pressing the **UP** and **DOWN** keys. Pressing either key for the first time, the LED readout will display the last temperature setting. (The temperature is preset to **0°F / -18°C**).
- To set the temperature, press the **UP** key to increase by 1°F / 1°C with each press. Press the **DOWN** key to decrease by 1°F / 1°C with each press.
- The range of the temperature control is from **-11°F to 11°F** (-24°C to -12°C).
- To view the set temperature at any time, press the **UP** or **DOWN** key. The set temperature will flash in the display window for 5 seconds. After 5 seconds, the temperature inside the unit will reappear on the display window.

#### **NOTE:**

- If the unit is unplugged, or there is a power loss or shutdown, wait **3–5 minutes** before restarting. The unit will not start if you try sooner.
- When first using the unit, or after it has been off for a long time, the temperature on the display may differ slightly from the set temperature. This is normal and will correct itself after a few hours of operation.

### **Interior Light**

The interior light makes it easy to view your items. Press and hold the **DOWN** key for 5 seconds to toggle between the two lighting modes, **Functional** (default) and **Showcase**.

- **Functional Mode:** The light will turn on when the door is open and automatically turn off about 5 seconds after the door is closed.
- **Showcase Mode:** The light will remain on if the door is closed.

The interior LED lights are designed for long life and are not user replaceable. For replacement assistance, please contact our service department.

**NOTE:** Only use the original LED light fittings provided by the manufacturer.

## Sabbath Mode

Sabbath Mode is available for the observance of certain religious holidays. This mode turns off the displays, interior light and audible alarms and prevents them from turning on again. Normal cooling operations will still take place.

To initiate Sabbath Mode, press the **POWER** and **LIGHT** or **SUPERFREEZE** keys at the same time for 5 seconds. The temperature display will go out to confirm that the Sabbath Mode is **ON**.

Sabbath mode can be canceled by repeating the above process. The Sabbath Mode will automatically turn **OFF after 96 hours**.

## Temperature Memory Function

In the event of a power interruption the unit can remember the previous temperature settings, and when the power is recovered, the cabinet temperature will return to the same setting temperature as before the power went off.

## Defrosting

- The unit defrosts automatically in normal operating conditions.
- The evaporator behind the rear wall of the unit defrosts automatically. The condensate collects in the drainage channel behind the rear wall of the unit and flows through the drainage hole into the drip tray by the compressor where it evaporates.
- However, frost may accumulate on the evaporator if the unit is repeatedly opened in a high heat or high humidity location. If this frost pattern does not clear within 24 hours, your unit will require manual defrosting.

## Using the Freezer (if available)

- These freezers are designed for the long-term storage of frozen food. Storage time is up to three months.
- The storage life of frozen foods varies, and the recommended storage time should not be exceeded.
- Pre-packaged commercially frozen food should be stored in accordance with the frozen foods manufacturer's instructions for a three star frozen food storage compartment or home freezer.
- Place frozen food into the freezer as quickly as possible after purchase. If there are instructions on the packet, carefully follow these instructions regarding storage times.

## Temperature Alarm / Door Alarm

- An audible alarm sounds if the storage temperature is not cold enough. The temperature display flashes at the same time.
- The cause of the temperature being too high may be:
  - Warm fresh food was placed inside
  - Too much warm ambient air flowed in when rearranging and removing food
  - Power failure for some time
  - The appliance is faulty
- The audible alarm is automatically silenced and the temperature display stops flashing when the temperature is sufficiently cold again.
- If the door has been left open for more than 60 seconds, the alarm will sound. Pressing the **POWER** key once can switch off the audible alarm.

## Door Lock

Your unit provided a lock and key combination.

The keys are located inside the plastic bag that contains the *User Manual*.

Insert the key into the lock and turn it counterclockwise to unlock the door. To lock the door, do the reverse operation, ensure the metal pin is engaged completely. Remove the key and put it in a secure place for safekeeping.

## Shelves

To prevent damaging the door gasket, make sure to have the door all the way open when pulling the shelves out of the rail compartment.

- Any of the shelves can be removed to store larger items.
- When removing the shelf from the rail compartment, make sure to remove all items first. Then move the shelf to the position where the notch of the shelf is exactly under the plastic post and lift the shelf. In order to replace the shelf, repeat the steps described above in reverse.

### CAUTION:

When removing or replacing the shelf, use caution not to scratch the sides of the unit.

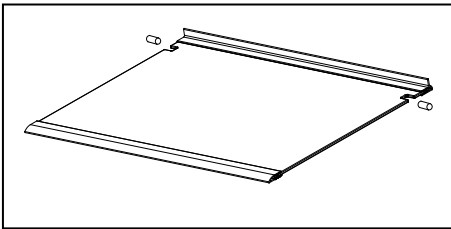

## Cantilevered Shelves

Any of the shelves can be removed to store larger items.

- When removing the shelf, make sure to have the door all the way open and remove all items first. Hold the front of the shelf, and then gently lift up and move out toward you.
- In order to replace the shelf, hold the shelf at an angle so the front is higher than the back, and then insert the top hook into the notch of clip-in strip. Then, lower the shelf and insert the bottom shelf hook into the notch of clip-in strip.

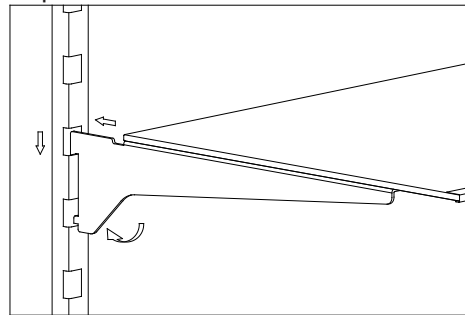

## Door Racks

To remove the door racks, lift them up and then pull them out straight.

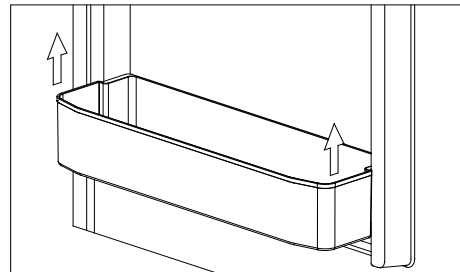

# CARE AND MAINTENANCE

## Cleaning Your Appliance

- Turn off the power, unplug the appliance, and remove all items, including shelves.
- Wash the inside surfaces with a solution of warm water and baking soda (about 2 tablespoons of baking soda to a quart of water).
- Wash the shelves with a mild detergent solution.
- Wring excess water out of the sponge or cloth when cleaning the area where the controls are located, or any electrical parts.
- Wash the outside cabinet with warm water and mild liquid detergent. Rinse well and wipe dry with a clean, soft cloth.
- Use an approved stainless steel cleaner to clean the door and handle. Do not use steel wool or a steel brush on the stainless steel.

### CAUTION:

Failure to unplug the appliance during cleaning could result in electrical shock or other personal injury.

## Power Failure

Most power failures are corrected within a few hours and should not affect the temperature of your appliance if you minimize the number of times the door is opened. If the power is going to be off for a longer period of time, you need to take the proper steps to protect the contents.

## Vacations

- **Short vacations:** Leave the appliance operating during vacations of less than three weeks.
- **Long vacations:** If the appliance will not be used for several months, remove all items, and turn off the appliance. Clean and dry the interior thoroughly. To prevent odor and mold growth, leave the door open slightly, blocking it open if necessary.

## Moving Your Appliance

1. Remove all items.
2. Securely tape down all loose items (shelves) inside your appliance.
3. Turn the adjustable legs up to the base to avoid damage.
4. Tape the door shut.
5. Be sure the appliance stays secure in the upright position during transportation. Also, protect the outside of the appliance with a blanket or similar item.

## Energy-Saving Tips

- The appliance should be located in the coolest area of the room or outdoor location, away from heat-producing appliances and out of direct sunlight.
- Ensure that the unit is adequately ventilated. Never cover air vents.
- Do not keep the door open any longer than necessary.
- Let hot foods cool to room temperature before placing in the unit. Overloading the unit forces the compressor to run longer.
- Be sure to wrap foods properly, and wipe containers dry before placing them in the unit. This cuts down on frost build-up inside the unit.
- Unit shelves and storage bins should not be lined with aluminum foil, wax paper, or paper toweling. Liners interfere with cold air circulation, making the unit less efficient.
- Organize and label food to reduce door openings and extended searches. Remove as many items as needed at one time and close the door as soon as possible.

# TROUBLESHOOTING

You can solve many common problems easily, saving you the cost of a possible service call. Try the suggestions below to see if you can solve the problem before calling the servicer.

<b>PROBLEM</b>	<b>POSSIBLE CAUSE</b>	<b>REMEDY</b>
<i>Appliance does not operate.</i>	<i>Appliance is not connected to a power supply. The appliance is turned off. Tripped circuit breaker or a blown fuse.</i>	<i>Connect the appliance.  Switch on the appliance. Switch on circuit breaker or replace fuse.</i>
<i>Appliance is not cold enough.</i>	<i>The temperature is not set correctly. The ambient temperature could require a lower set temperature setting. The door was opened too often.  The door was not closed completely. Door is not hermetically sealed.  The condenser is dirty.  The ventilation opening is blocked or too dusty.</i>	<i>Check the set temperature. Set a lower temperature.  Do not open the door more often than necessary. Close door properly. Check the door seal and clean or replace. Clean the condenser when necessary.  Clear the obstructions and clean off the dust.</i>
<i>Appliance turns itself on and off frequently.</i>	<i>The room temperature is higher than average. A large number of items have been added to the unit.  The door is opened too often.  The door is not closed completely. The door gasket does not seal properly.</i>	<i>Put the appliance in a cooler place.  Leave the appliance to work for a while until the set temperature has been reached. Do not open the door more often than necessary. Close door properly. Check the door seal and clean or replace.</i>
<i>The light does not work.</i>	<i>Appliance is not connected to a power supply. Tripped circuit breaker or a blown fuse. The light was switched off on the control panel.</i>	<i>Connect the appliance.  Switch on circuit breaker or replace fuse. Switch on the light.</i>
<i>Vibrations</i>	<i>The appliance is not properly leveled.</i>	<i>Level the appliance with the adjustable feet.</i>
<i>The appliance seems to make too much noise.</i>	<i>A rattling noise may come from the flow of the refrigerant, which is normal. As each cycle ends, you may hear gurgling sounds caused by the flow of refrigerant in your appliance. If temperature fluctuations occur, the contraction and expansion of the inner walls may cause popping and crackling noises.</i>	
	<i>The appliance is not properly leveled.</i>	<i>Level the appliance with the adjustable feet.</i>
<i>The door will not close properly.</i>	<i>The appliance is not properly leveled.  The door was reversed and not properly re-installed. The gasket is dirty. The shelves are out of position.</i>	<i>Level the appliance with the adjustable feet. Check the door hinge and reassemble correctly. Clean the door gasket. Check the shelves and refit correctly.</i>

Display "E0", "E1", "E2", "E3", "E4", "E5", "E6" or "E7".	<p>"E0" indicates a communication error for 3- zone models.</p> <p>"E1" or "E2" indicates that the air temperature sensor has failed.</p> <p>"E3" or "E4" indicates that the defrost sensor in the evaporator has failed.</p> <p>"E5" indicates a defrost heater failure.</p> <p>"E6" indicates a solenoid valve failure.</p> <p>"E7" indicates a door switch failure.</p>	Call for service.
The alarm sounds and the temperature display flashes.	<p>Has the appliance door been open for longer than 60 seconds? If not, then the temperature has risen higher or fallen lower than the set temperature. This could be due to:</p> <p>The appliance door has been opened too often.</p> <p>The ventilation opening is covered or too dusty.</p> <p>A lengthy interruption to the power supply.</p> <p>A large number of items have been added to the unit.</p>	<p>If yes, close the door.</p> <p>Do not open the door more often than necessary.</p> <p>Clear the obstructions and clean off the dust.</p> <p>Let the appliance work for a while until the set temperature has been reached.</p>
The icon "--" is lit up and flashing in the temperature display.	The display temperature is out of range.	Only temperatures within the range 0~99°F/-9~37°C can be displayed. If the temperature is not within this range, the icon "--" will be displayed instead. This is normal.

If you have checked the information above and you still need help with your appliance, call our Customer Service facility at **800-932-4267** (Ext. **513**) between 9:00 AM and 5:00 PM ET or visit our website **summitappliance.com/support** at any time. We will do our best to answer your questions.

To order replacement parts, visit our website: **summitapplianceparts.com**



**WARNING:** This product can expose you to chemicals including Nickel (Metallic) which is known to the State of California to cause cancer.

For more information go to [www.P65Warnings.ca.gov](http://www.P65Warnings.ca.gov)

Note: Nickel is a component in all stainless steel and some other metallic compositions.

### **CALIFORNIA CARB/SNAP DISCLOSURE**

**This product uses eco-friendly hydrocarbon refrigerant and fully complies with California CARB regulations.**

However, we are required by California Law to provide the following disclosure statement in every product sold in California.

*"This equipment is prohibited from use in California with any refrigerants on the 'List of Prohibited Substances' for that specific end-use, in accordance with California Code of Regulations, title 17, section 95374. This disclosure statement has been reviewed and approved by Felix Storch, Inc. and Felix Storch, Inc. attests, under penalty of perjury, that these statements are true and accurate."*

This product does **not** use any refrigerants on the 'List of Prohibited Substances'"

# NOTES

# LIMITED WARRANTY

## ONE-YEAR LIMITED WARRANTY

Warranty coverage is available within the 48 contiguous United States, along with select areas of Alaska, Hawaii, and Canada. For locations not covered, consumers can either contact a local provider or coordinate with Felix Storch, Inc. to find nearby service options, which may qualify for partial reimbursement.

The warranty for this appliance is valid for one year from the date of purchase, provided the appliance is operated and maintained according to the instructions included with the product. The warrantor will cover the cost of factory-specified parts and repair labor needed to correct defects in materials or workmanship. Service must be performed by a designated service company.

All parts, except the compressor, are warranted for one year against manufacturing defects. Plastic parts, shelves, and cabinets are produced to commercially acceptable standards but are not covered for damages incurred during handling or for breakage.

## 5-YEAR COMPRESSOR WARRANTY

1. The compressor is covered for 5 years.
2. Replacement does not include labor.

## ITEMS WARRANTOR WILL NOT PAY FOR:

1. Service calls to correct the installation of your appliance, to instruct you how to use your appliance, to replace or repair fuses or to correct wiring or plumbing.
2. Service calls to repair or replace appliance light bulbs or broken shelves. Consumable parts (such as filters) are excluded from warranty coverage.
3. Damage resulting from accident, alteration, misuse, abuse, fire, flood, acts of God, improper installation, installation not in accordance with electrical or plumbing codes, or use of products not approved by warrantor.
4. Replacement parts or repair labor costs for units operated outside the 48 contiguous United States, along with select areas of Alaska, Hawaii, and Canada.
5. Repairs to parts or systems resulting from unauthorized modifications made to the appliance.
6. Expenses for travel and transportation for product service in remote locations.
7. The removal and reinstallation of your appliance if it is installed in an inaccessible location or is not installed in accordance with published installation instructions.

## DISCLAIMER OF IMPLIED WARRANTIES; LIMITATION OF REMEDIES

CUSTOMER'S SOLE AND EXCLUSIVE REMEDY UNDER THIS LIMITED WARRANTY SHALL BE PRODUCT REPAIR AS PROVIDED HEREIN. IMPLIED WARRANTIES, INCLUDING WARRANTIES OF MERCHANTABILITY OR FITNESS FOR A PARTICULAR PURPOSE, ARE LIMITED TO ONE YEAR. WARRANTOR SHALL NOT BE LIABLE FOR INCIDENTAL OR CONSEQUENTIAL DAMAGES. SOME STATES DO NOT ALLOW THE EXCLUSION OR LIMITATION OF INCIDENTAL OR CONSEQUENTIAL DAMAGES, OR LIMITATIONS ON THE DURATION OF IMPLIED WARRANTIES OF MERCHANTABILITY OR FITNESS, SO THESE EXCLUSIONS OR LIMITATIONS MAY NOT APPLY TO YOU. THIS WARRANTY GIVES YOU SPECIFIC LEGAL RIGHTS AND YOU MAY ALSO HAVE OTHER RIGHTS, WHICH VARY FROM STATE TO STATE.

Revised: 2026-01-22