



Service Manual Professional Washing Machine

Type: WM70.C



## Contents

Updates.....	4
Introduction.....	5
General product information.....	6
Troubleshooting strategy.....	6
Panel.....	7
Knob and button descriptions.....	7
LCD description.....	7
Settings.....	8
Service menu.....	9
Service menu content.....	10
Notes for custom programmes.....	13
Making a custom programme.....	14
Program chart.....	15
Fault indicators.....	18
Components and measurement values.....	19
Thermistor measurement values.....	20
Technical data.....	21
Tools.....	21
Wiring diagram.....	22
Panel and control card replacement.....	32
Wash agitator removal.....	34

## Updates

Rev	Date	Description	Initials
01	2010-07-12	First version developed	BPA
02	2011-11-17	New document structur and updated wiring diagrams	ISC
03	2012-04-20	Removed chapter General information, programme tables and added reference to use the user manual.	BPA
04	2012-09-17	Updated with new version of circuit diagram 80 896 27 Ver01	BPA
05	2012-10-01	Added programme chart with new Allergy programmes	BPA

## Introduction

You are holding the service manual for WM70.C washing machines.

It should be easy to service a washing machine. It is important that you, as a service technician, are provided the necessary conditions to work in an efficient and satisfactory manner. Our hope is that this service manual will prove a useful tool in your daily work.

The type plate is located on the inside of the front door (see image below).

Asko Appliances AB  
SE-534 82 Vara  
Sweden

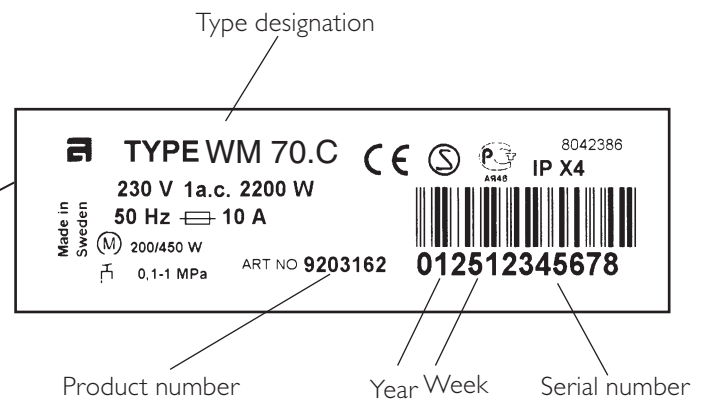

## BRUKSANVISNING

Ha alltid maskinens bruksanvisning tillgänglig vid service

### Troubleshooting strategy

At Asko, we believe in always remaining focused on the customer, and as an ASKO service technician, you are one of the most important ambassadors of our brand. As such, it is important that the customer finds the service callout a pleasant experience. Troubleshooting is an important part of the service callout, and as such we have drawn up a troubleshooting strategy that describes, in broad terms and step by step, what you need to do to find and diagnose faults.

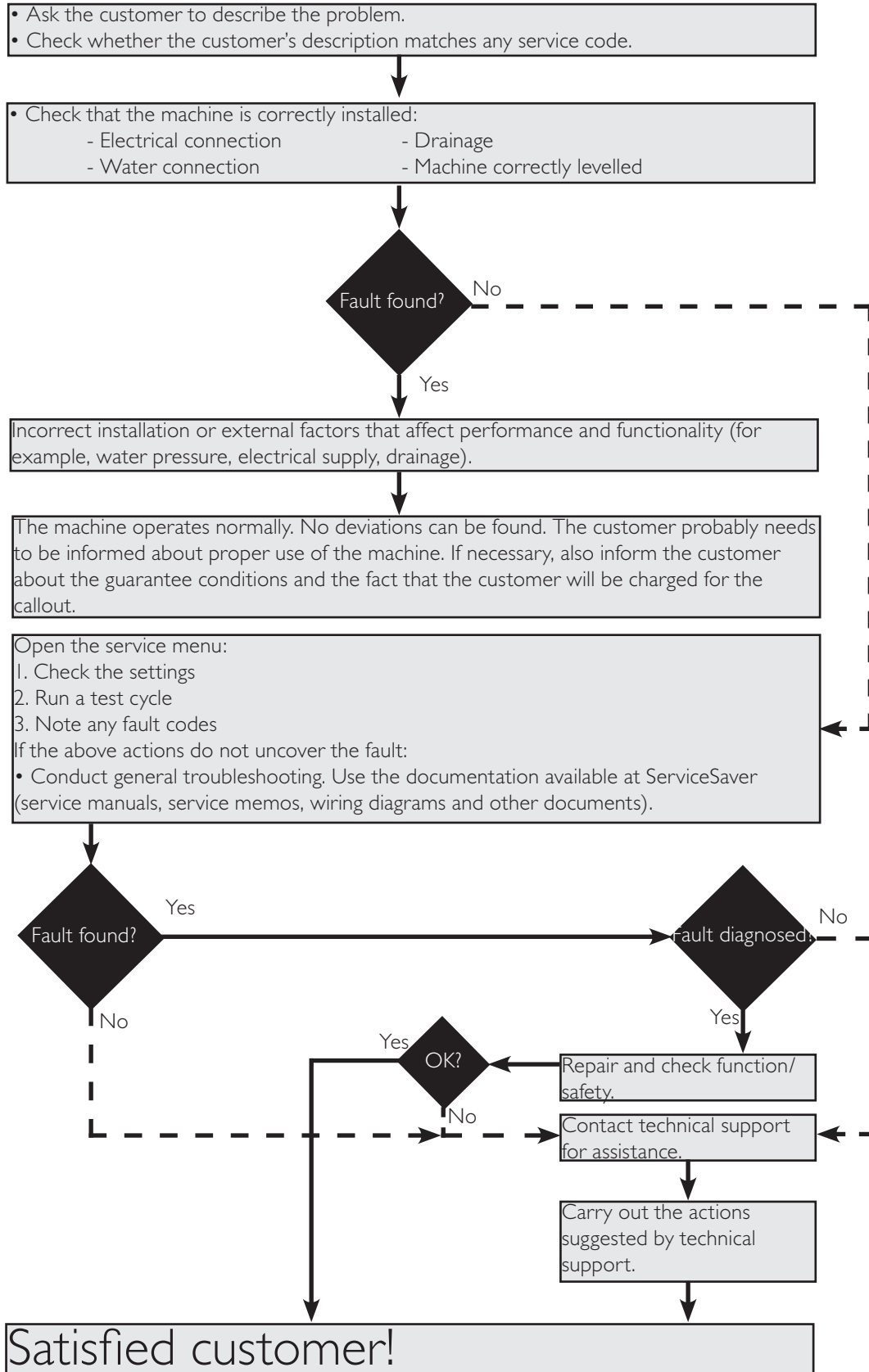



## Panel WM70.C



**Programmes:** A total of twenty-two programmes, three of which can be customised via the service menu. A maximum of ten programmes can be activated/available to the end user at the same time.

**Settings:** Four (Language, Child-safe start, Automatic door opening, Temperature)

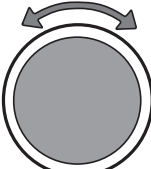
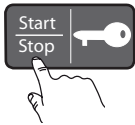

### Knob and button descriptions



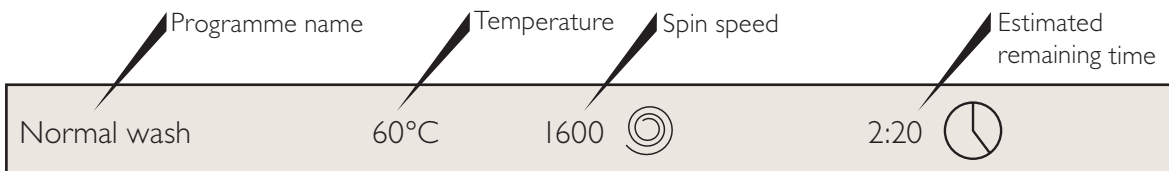

	<p>Programme selector Turn clockwise or anti-clockwise to cycle through the different programmes and options in the various menus.</p>
	<p>Start/Stop button</p> <ul style="list-style-type: none"> <li>• Start programme</li> <li>• Stop programme. Press and hold for 3 seconds.</li> </ul>
	<p>Key button</p> <ul style="list-style-type: none"> <li>• Opens the door once the programme has ended.</li> <li>• Opens the door during a programme to add more laundry.</li> <li>• Confirm selection in the settings and service menus.</li> </ul>

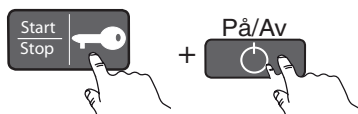
### LCD description

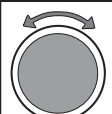

## Settings

Opening the settings menu	
	<p>Is the machine on? First turn off the power at the main power switch (S1). Press and hold the Key button (S5) while simultaneously pressing the main power switch (S1).</p>
	<p>Press the Key button (S5) 5 times within 10 seconds. The settings menu now opens.</p>

Choosing a setting (an example)	
1	 <p>Turn the programme selector (J1) to cycle through the settings menu options.</p>
2	 <p>Press the Key button (S5) to select an item in the settings menu.</p>
3	 <p>Turn the programme selector (J1) to cycle through the different options for that setting.</p>
4	 <p>Press the Key button (S5) to select one of the settings.</p>
5	 <p>Press the Start/Stop button (S4) to save the settings and return to the programme menu.</p>







Service menu content		Comments
Language	US English	Note: The language used under "Special" in the service menu is not changed (English only).
	English	
	Svenska	
	Dansk	
	Norsk	
	Suomi	
	Français	
	Deutsch	
	Italiano	
	Espanol	
	<b>Русский</b>	
	Nederlands	
Child-safe	Child-safe Off	You can temporarily disable Child-safe start by pressing the Start/Stop button and the Key button simultaneously.
	Child-safe On	
Door opening	Door opening Off	
	Door opening On	

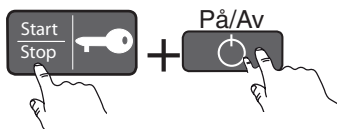
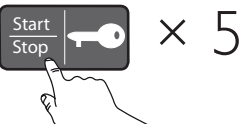

... continuous

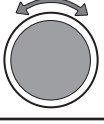
°C/°F	°C	
	°F	
Water inlet	Cold	Valid for products manufactured from February, 2012. For products manufactured before February 2012, see service menu setting 21.
	Hot	

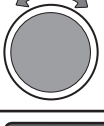
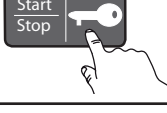
## Service menu

Opening the service menu		
		If the machine is on: First turn off the power at the main power switch (SI). Press and hold the Start/Stop button (S4) while simultaneously pressing the main power switch (SI).
		Press the Start/Stop button (S4) 5 times within 5 seconds. The service menu now opens.
Navigating the service menu		
1		Turn the programme selector (JI) to cycle through the different service menu options. - 1 Service - 2 Settings - 3 Special
2		Press the Key button (S5) to select an option in the service menu.
3		Turn the programme selector (JI) to cycle through the different settings.
4		Press the Key button (S5) to select a setting.
5		Turn the programme selector (JI) to select one of the options.
6		Press the Key button (S5) to confirm/save or go back one step.
7	or 	Press the Start/Stop button (S4) to return to the programme menu or use the programme selector to make additional choices.  <b>NB:</b> The different options in the service menu vary in terms of the number of alternative selections and settings.



## Service menu content (cont.)

2 Settings	21 Water inlet	Cold	Valid for products manufactured before February 2012.
		Hot	
	21 HWC	Off (default)	Valid for products manufactured from February 2012.
		On	
	22 Max RPM	400 rpm	This function only works for programmes Pr1-Pr19.
		600 rpm	
		800 rpm	
		1000 rpm	
		1200 rpm	
		1300 rpm	
		1400 rpm	
		1500 rpm	
	23 Drain	Pump	
		Valve	
	24 Show temp	Temp Off	Only applies to the disinfection programmes (Pr17-Pr19)
		Temp On	
25 Change temp	Pr1-Pr25	This can be changed in steps of 1°C between -10°C to +10°C. You cannot set a total temperature that exceeds +92°C.	
26 Programs	Pr1-Pr28	Select "On" or "Off"  Programmes can be activated/deactivated. A deactivated programme is not shown on the display.  A maximum of 10 programmes can be shown on the display in programme mode. If more than 10 programmes are activated, then only the first ten activated programmes are shown on the display.  If all the programmes have been deactivated, the display only shows "Pr1".  If the machine is Swan-labelled, "Pr1" and "Pr2" are always activated/On.	
27 Spin time	0-300 sec	<ul style="list-style-type: none"> <li>Extend or shorten the spin time: 0-300 sec.</li> <li>If "0 sec" is selected, the pre-programmed spin time is used.</li> <li>If a time in the interval "1 sec" to "300 sec" is selected, this time is added to the pre-programmed spin time.</li> <li>This function only works for programmes Pr13 and Pr14.</li> </ul>	
28 Coin	Coin Off	See the wiring diagram for the correct connection and functionality of a slot meter.	
	Coin On		
29 Reset	Only production reset	Used only in production	
210	Off (default)	When On is choosed it shall be possible to temporally change to language in the machine. The language shall return to selected machine language (selected in the user menu) when the program is finished. This menu step is placed after program 28.	
	On		
Return	Press the Key button (S5) to return to 2 Settings.		

## Service menu content (cont.)

3 Special	Pr 26	34 Pre wash	341 Number of	0/1/2/3
			342 Water level	Normal water level/High water level
			343 Time	1/2/3/4/...../15 (min)
			344 Heat temp	No heat/25°C/26°C/...../60°C
			Return	
		35 Main wash	351 Temperature	30°C/31°C/...../92°C
			352 Water level	Normal water level/High water level
			353 Reheat temp	28°C/29°C/...../90°C
			354 Reheat time	0min/1min/...../60°C
			355 Work time	0min/1min/...../60min
			Return	
		36 Rinses	1 Rinse/2 Rinse/...../7 Rinses	
		37 Extra spin	On/off	
		38 Spin speed	400/600/800/1000/1200/1300/1400/1500/1600 RPM	
	39 Spin time	0-300 sec		
	Return	Press the Key button to return to the previous menu level.		
	Pr 27	See above		
	Pr 28	See above		
	Return	Press the Key button (S5) to return to 3 Special.		

Notes for custom programmes

Save these notes for future reference!

Make a note of the settings you make when creating custom programmes (Pr20, 21, 22).









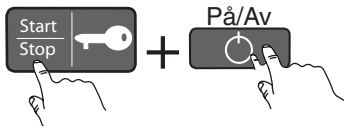

Save this note close to the machine









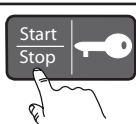

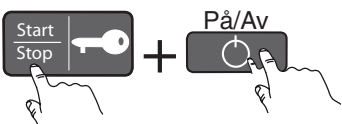
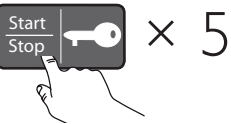

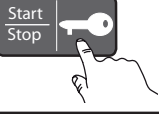
			Notes
Pr 26	34 Pre wash	341 Number of	
		342 Water level	
		343 Time	
		344 Heat temp	
	35 Main wash	351 Temperature	
		352 Water level	
		353 Reheat temp	
		354 Reheat time	
		355 Work time	
	36 Rinses		
	37 Extra spin		
	38 Spin speed		
	39 Spin time		
Pr 27	34 Pre wash	341 Number of	
		342 Water level	
		343 Time	
		344 Heat temp	
	35 Main wash	351 Temperature	
		352 Water level	
		353 Reheat temp	
		354 Reheat time	
		355 Work time	
	36 Rinses		
	37 Extra spin		
	38 Spin speed		
	39 Spin time		
Pr 28	34 Pre wash	341 Number of	
		342 Water level	
		343 Time	
		344 Heat temp	
	35 Main wash	351 Temperature	
		352 Water level	
		353 Reheat temp	
		354 Reheat time	
		355 Work time	
	36 Rinses		
	37 Extra spin		
	38 Spin speed		
	39 Spin time		

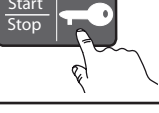

## Making a custom programme

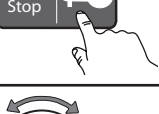
You can make three custom programmes. This is done in the service menu. In order for the new programme to be made available, one of the existing programmes must be deactivated, that is, set to "Off", and the new programme set to "On". See also the "3 Special" section of the "Service menu content" chapter.

Opening the service menu		
		If the machine is on: First turn off the power at the main power switch (S1). Press and hold the Start/Stop button (S4) while simultaneously pressing the main power switch (S1).
		Press the Start/Stop button (S4) 5 times within 5 seconds. The service menu now opens.
Programming		
1		Turn the programme selector (J1) to "3 Special".
2		Press the Key button (S5) to open the "3 Special" menu.
3		Turn the programme selector (J1) to cycle through the different options: Pr20, Pr21, Pr22 and Return.
4		Press the Key button (S5) to open one of the options, Pr20, Pr21 or Pr22. Now you can create your programme by selecting from the various options and settings.
5		Turn the programme selector (J1) to cycle through the different menus: -34 Pre wash -35 Main wash -36 Rinses -37 Extra spin -38 Spin speed -39 Spin time Return
6		Press the Key button to open one of the menus.
7		Turn the programme selector (J1) to cycle through the different menu options.
8		Press the Key button to save the setting and return to the previous menu level. Repeat steps 5 to 8 to programme the remaining settings.
9		Once you have finished creating the programme, press the Start/Stop button (S4) to return to the programme menu.

Activate the new programme		
1		If the machine is on: First turn off the power at the main power switch (S1). Press and hold the Start/Stop button (S4) while simultaneously pressing the main power switch (S1).
2		Press the Start/Stop button (S4) 5 times within 5 seconds. The service menu now opens.
3		Turn the programme selector (J1) to "2 Settings".
4		Press the Key button (S5) to open the "2 Settings" menu.
5		Turn the programme selector (J1) to "26 Programs".
6		Press the Key button (S5) to open the "26 Programs" menu.
7		Turn the programme selector (J1) to select the programme you want to deactivate.
8		Press the Key button to open the menu.
9		Turn the programme selector to "Off" to deactivate the programme.
10		Press the Key button (S5) to confirm/save.
11		Activate your new programme by turning the programme selector to the programme you want to activate.
12		Press the Key button to open the menu.
13		Turn the programme selector to "On" to activate the programme.
14		Press the Key button to confirm/save.

## Programmes

Programme name	Description
1. Normal wash (USA: Normal Hot) 60°C	Programme for normally to heavily soiled laundry, whites and colours. Follow the washing instructions for each garment. 60°C is a good temperature for garments worn next to the skin. This programme has five rinses.
2. Normal wash (USA: Normal Warm) 40°C	Programme for normally to heavily soiled laundry, whites and colours. Follow the washing instructions for each garment. This programme has five rinses.
3. Heavy wash 90°C	Programme for heavily soiled laundry, with dirt that needs to be fully dissolved before the main wash. A pre-wash is used to do this.
4. Heavy wash 60°C	Programme for heavily soiled laundry, with dirt that needs to be fully dissolved before the main wash. A pre-wash is used to do this.
5. White (USA: Sani) 90°C	Programme for normally to heavily soiled laundry. Follow the washing instructions for each garment. 90°C is a good temperature for white and light-coloured cotton, such as bed linen.
6. White/Colour (USA: White) 60°C	Programme for normally soiled laundry, whites and colours. Follow the washing instructions for each garment. 60°C is a good temperature for garments worn next to the skin.
7. White/Colour (USA: Colour) 40°C	Programme for normally soiled laundry, whites and colours. Follow the washing instructions for each garment.
8. Super quick wash (USA: Quick wash) 60°C	Fast programme for laundry that just needs freshening up. Follow the washing instructions for each garment. Garments worn next to the skin ought to be washed at 60°C.
9. Super quick wash 40°C	Fast programme for laundry that just needs freshening up. Follow the washing instructions for each garment.
10. Synthetics (USA: PermaPress) 40 °C	Programme for synthetics, delicate blended materials and permanent press cotton. Suitable for shirts and blouses. Follow the washing instructions for each garment. Many synthetics will come clean at 40°C.
11. Wool/hand wash 30°C	A gentle laundry programme for wool, silk and garments that should be washed by hand. This programme has a short spin.
12. Rinse	This programme performs one cold rinse cycle + spin. Suitable for laundry that just needs to be dampened.
13. MOP wash 60°C	Programme suitable for different types of mop. The programme has two rinses using much water.
14. MOP wash 90°C	Programme suitable for different types of mop. The programme has two rinses using much water.
15. Micro fibre wash 60°C	Programme for laundry made of micro fibres, such as micro-fibre cloths. The programme has three rinses with much water in the first rinse.
16. Micro fibre wash 40°C	Programme for laundry made of micro fibres, such as micro-fibre cloths. The programme has three rinses with much water in the first rinse.
17. Disinfection 40°C	Programme where the temperature reached during the main wash is maintained for 20 minutes. Disinfection at this temperature requires special detergent.
18. Disinfection 60°C	Programme where the temperature reached during the main wash is maintained for 20 minutes. Disinfection at this temperature requires special detergent.
19. Disinfection 90°C	Programme where the temperature reached during the main wash is maintained for 10 minutes. This temperature is sufficient for disinfection without special detergent.
20. Allergy cotton 90°C	



21. Allergy cotton 60°C	
22. Allergy cotton 40°C	
23. Allergy synthetic 60°C	
24. Allergy synthetic 40°C	
25. Cleaning	
26. Program 26	Programmable
27. Program 27	Programmable
28. Program 28	Programmable

## Fault indicators

Error message	Cause	Action
Over flow fault	Too much water in the machine.	Service action: Check the machine's level system, inlet valve and drainage pump. Check for any leaks.
	The drainage pump is running but the machine is empty.	
Water outlet fault	<ul style="list-style-type: none"> <li>• The drainage pump has been running for 3 minutes. Water remains in the machine.</li> <li>• The wash cycle is stopped and the programme is reset.</li> </ul>	<ol style="list-style-type: none"> <li>1. Check that nothing is stuck in the drainage hose outlet.</li> <li>2. Check that the drainage pump is not blocked by foreign objects.</li> <li>3. Check that there are no kinks in the drainage hose.</li> </ol> Service action: <ol style="list-style-type: none"> <li>1. If the pump only runs for a short while (approximately 20 seconds), this indicates a fault in the level system. Check the level sensor and hoses.</li> <li>2. Check the wiring and voltage to the pump. If necessary, replace the pump and/or control unit.</li> <li>3. After taking corrective action, run the Drain programme or press the Key (door opening) button to empty the machine.</li> </ol>
Water inlet fault	If the correct water level is not achieved within five minutes the wash cycle will be stopped.	<ol style="list-style-type: none"> <li>1. Check that the tap on the water pipe is open.</li> </ol> Service action: <ol style="list-style-type: none"> <li>1. Check that the filter in the machine's water intake is not blocked.</li> <li>2. Check the inlet valve. If necessary, replace the valve.</li> <li>3. Check the voltage to the inlet valve. If there is no voltage, this could be due to a fault in the level system, wiring or control unit.</li> </ol>
Security fault	The door is open	Close the door
Thermistor fault	<ol style="list-style-type: none"> <li>1. Thermistor circuit open</li> <li>2. Thermistor malfunction</li> <li>3. The measurement value for the thermistor is <math>&lt;300 \Omega</math> (<math>&gt;120^{\circ}\text{C}</math>)</li> </ol>	Service action: Check the thermistor. Replace if necessary.
Temperature fault	<p>The temperature has increased <math>&lt; 5^{\circ}\text{C}</math> in ten minutes</p> <p>The wash cycle should continue to the next step of the programme.</p>	Service action: Check the thermistor, heater, wiring and level system.
Wash motor fault	No signal from the tacho or MCU.	Service action: Check the output signal from the MCU and the wiring between the motor and the MCU.
Pressure fault	Indicated if the level drops to zero within 30 seconds of the first rinse.	Service action: Check for leaks.

## Components and measurement values

Item number	Component	Measurement value	Comment
80 658 33	CIM motor	Resistances: Pins 1-3 stator 3.7 $\Omega$ Pins 1-2 stator 3.6 $\Omega$ Pins 2-3 rotor 3.6 $\Omega$ Pins 4-5 tacho 178 $\Omega$	
80 617 03 80 617 04	Heating element 2000 W Heating element 1000 W		
80 761 02	Thermistor	6.1–3.8 k $\Omega$ (at room temperature 20–30°C)	The thermistor for measuring temperature is located between the motor cradle and the drum. The thermistor measures and controls the water temperature, which can vary from 0 to 92°C. The heater is disconnected if the thermistor is short-circuited or disconnected from the programme control card.
88 012 63	Drainage pump 50 Hz	144 $\Omega$	The drainage pump is combined with an integrated fine filter trap, which can be cleaned by the user. If the drainage pump has run for 3 minutes during draining, the programme stops, resets and a fault code is indicated on the display. The pump has a capacity of 20 litres/minute.
88 012 64	Drainage pump 60 Hz	76 $\Omega$	
80 782 21	Level switch		Electromechanical level switch with two levels (see wiring diagram). Used to indicate levels for door opening, heat and overflow.
80 762 02	EMC filter 50/60 Hz	680 $\Omega$	The filter eliminates interference to and from the machine.
80 793 24	Inlet valve	3.7 k $\Omega$ $\pm$ 0.5 k $\Omega$	Two-way inlet valve, 8 litres/minute
80 798 73	Door lock	122 $\Omega$	The door lock is electromechanical and equipped with a magnet.
80 833 15	One-way inlet valve		
80 818 07	Motor control		
80 806 28	Control unit		
80 833 43	Communication unit		
80 083 65	Outlet valve		

## Thermistor measurement values

Temp, °C	Resistance, ohm
0	15806
10	9634
20	6046
25	4841
30	3900
40	2579
50	1744
60	1204
70	848
80	609
85	519

## Technical data

Height:	850 mm
Width:	595 mm
Depth:	585 mm
Weight:	73 kg
Cylinder volume:	60 l
Max. load capacity	8 kg/6 kg
Spin speed:	800-1600
Connection:	1-phase 16 A, 3-phase 10 A
Heater output:	2000 W/3000 W
Water pressure/inlet valve:	0.1–1 MPa, 1–10 kp/cm <sup>2</sup> , 10–100 N/cm <sup>2</sup> 8 l/min
Wash drum and liquid compartment:	Stainless steel
Outer panels:	Powder-coated and hot-galvanised sheet steel or stainless steel
Installation:	Stationary on four adjustable, rubber-clad feet
Water connection:	1.5 m PEX tubing, 3/4"–3/4" or 3/4"–1/2"
Drainage:	1.7 m polypropylene tubing
Protection class:	IP X4
Water consumption (tested normal programme)	59 litres, 3 rinses (5 kg/6 kg) <72 litres, 5 rinses (6 kg) <69 litres, 5 rinses (5 kg)
Water consumption (tested normal programme)	1.02 kWh (6 kg) 0.95 kWh (5 kg)
Electricity consumption, Standby:	
- Machine turned off	<0.3 W
- Delayed start	<6.0 W
- Programme ended	<3.0 W

## Tools

Torx: T25, T20, T10
Ring spanner: 11/16", 16 mm, 13 mm, 10 mm
Socket screwdriver 10 mm
Extended socket 24 mm + ratchet handle
Allen key 5 mm + small ratchet handle
Plastic hammer
Phillips screwdriver
Wire cutter

# Wiring diagram WM70.C

- WIRES IN ALL MACHINES
- · — WIRES IN SOME MACHINES
- - - INTERNAL CONNECTION

### CABLE POSITIONS

- 1: MOTOR COMMUNICATION
- 2: THERMISTOR
- 3: INLET VALVES
- 4: DOOR LOCK, DRAIN PUMP, PREASSURE SWITCH
- 6: COMMUNICATION INTERFACE
- 7: COIN COLLECTOR
- 8: POWER
- 9: HEATING ELEMENT, PREASSURE SWITCH
- 10: MOTOR POWER

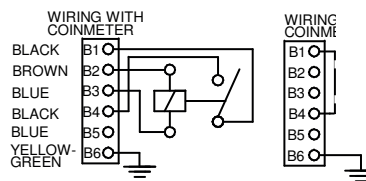
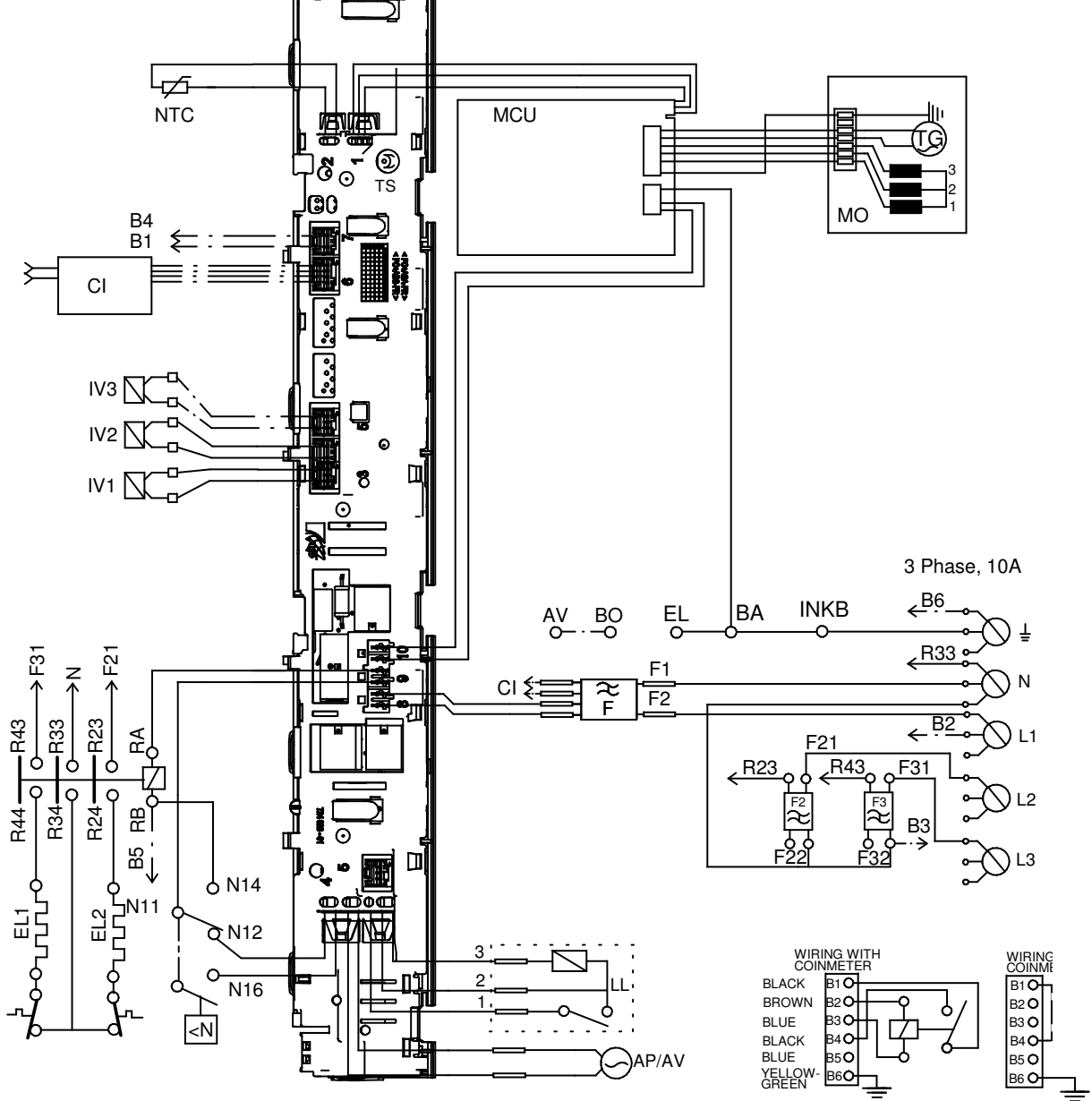

RESISTANCES AT ROOM TEMPERATURE (CA. 20°C/68°F)  
 VALUES WITHIN +/-10% ARE REGARDED AS NORMAL COMPONENT

F: RADIO INTERFERENCE SUPPRESSION FILTER	680K Ohm
EL: HEATING ELEMENT	25 Ohm
AP: DRAIN PUMP 50 Hz	144 Ohm
AP: DRAIN PUMP 60 Hz	76 Ohm
AV: DRAIN VALVE	110/134 Ohm
LL: DOOR LOCK, 1-2	122 Ohm
NTC: THERMISTOR	6.1 - 3.8 K Ohm
IV 1: INLET VALVE 1	3.7 K Ohm
IV 2: INLET VALVE 2	3.7 K Ohm
IV3: INLET VLAVE 3	3.5 K Ohm
MO: MOTOR, 1-3	4,3±7% Ohm
1-2	4,3±7% Ohm
2-3	4,3±7% Ohm
MCU: MOTOR CONTROL UNIT	
N: PRESSURE SWITCH	
TS: PRESSURE SENSOR	
TG: TACHO GENERATOR	
BA: CONTAINER	
INKB: INCOMING GROUND	
CI: COMMUNICATIONS INTERFACE	

**USER SETTINGS MENU**  
 TURN OFF POWER (S1)  
 WAIT FOR AT LEAST 5 SEC  
 HOLD S5  
 TURN ON POWER (S1)  
 PRESS S5 5 TIMES TO ENTER MENU



**SERVICE MENU**

TURN OFF POWER (S1)  
 WAIT FOR AT LEAST 5 SEC  
 HOLD S4  
 TURN ON POWER (S1)  
 PRESS S4 5 TIMES TO ENTER SERVICE MENU

PRESS DOOR OPENING (S5) TO CHANGE MENU STEP  
 ROTATE DIAL TO CHANGE IN STEP  
 PRESSING START/STOP (S4) STORES AND EXITS SERVICE MENU

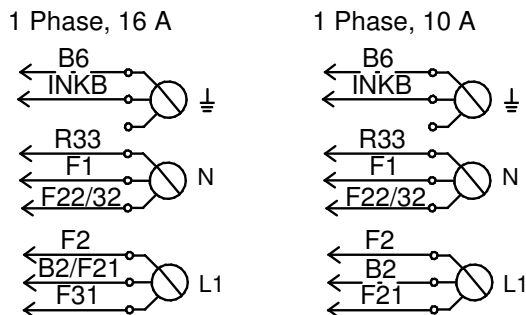

2010-05-20

CIRCUIT DIAGRAM WM70.C  
**80 886 19 - 00**

This document must not be copied without our written permission, and the contents thereof must not be imparted to a third party nor be used for any unauthorized purpose. Contravention will be prosecuted.  
 Asko Appliance AB

Wiring diagram WM70.C WC US/CA

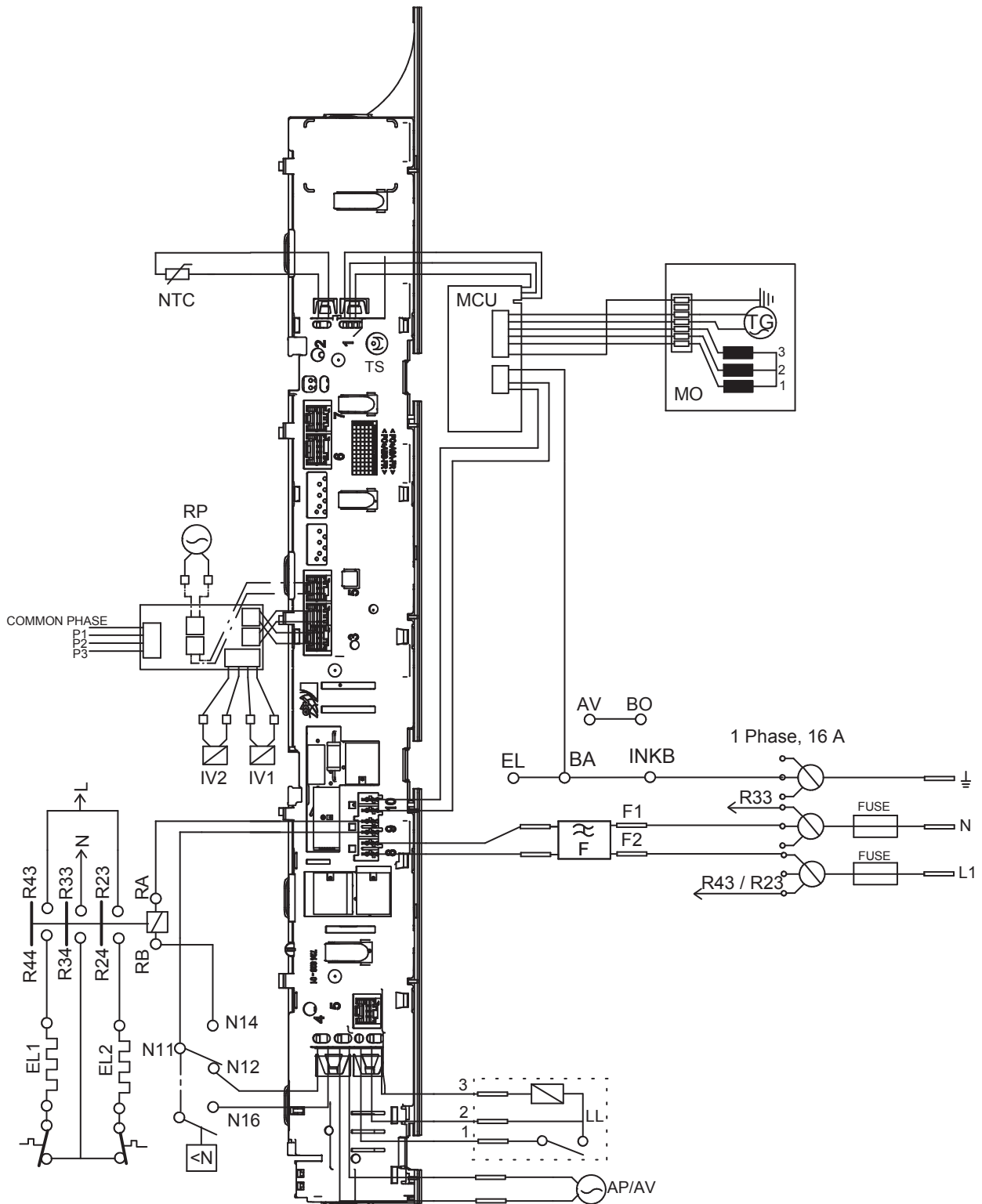



**CABLE POSITIONS**

- 1: MOTOR COMMUNICATION
- 2: THERMISTOR
- 3: INLET VALVES
- 4: DOOR LOCK, DRAIN PUMP, PREASSURE SWITCH
- 6: COMMUNICATION INTERFACE
- 7: COIN COLLECTOR
- 8: POWER
- 9: HEATING ELEMENT, PREASSURE SWITCH
- 10: MOTOR POWER

- WIRES IN ALL MACHINES
- · — WIRES IN SOME MACHINES
- - - INTERNAL CONNECTION

RESISTANCES AT ROOM TEMPERATURE (CA. 20°C/68°F)  
 VALUES WITHIN +/-10% ARE REGARDED AS NORMAL COMPONENT

F: RADIO INTERFERENCE SUPPRESSION FILTER	680K Ohm
EL: HEATING ELEMENT	25 Ohm
AP: DRAIN PUMP 50 Hz	144 Ohm
AP: DRAIN PUMP 60 Hz	76 Ohm
AV: DRAIN VALVE	110/134 Ohm
LL: DOOR LOCK, 1-2	122 Ohm
NTC: THERMISTOR	6.1 - 3.8 K Ohm
IV 1: INLET VALVE 1	3.7 K Ohm
IV 2: INLET VALVE 2	3.7 K Ohm
IV3: INLET VLAVE 3	3.5 K Ohm
MO: MOTOR, 1-3	4,3±7% Ohm
	2-3
MCU: MOTOR CONTROL UNIT	
N: PRESSURE SWITCH	
TS: PRESSURE SENSOR	
TG: TACHO GENERATOR	
BA: CONTAINER	
INKB: INCOMING GROUND	
CI: COMMUNICATIONS INTERFACE	
CM: COIN METER CABLES	

**SERVICEMENU**

- TURN OFF POWER (S1)
- WAIT FOR AT LEAST 5 SEC
- HOLD S4
- TURN ON POWER (S1)
- PRESS S4 5 TIMES TO ENTER SERVICE MENU

- PRESS DOOR OPENING (S5) TO CHANGE MENU STEP
- ROTATE DIAL TO CHANGE IN STEP
- PRESSING START/STOP (S4) STORES AND EXITS SERVICE MENU

**USER SETTINGS MENU**

- TURN OFF POWER (S1)
- WAIT FOR AT LEAST 5 SEC
- HOLD S5
- TURN ON POWER (S1)
- PRESS S5 5 TIMES TO ENTER MENU



**2011-04-14**

CIRCUIT DIAGRAM WM70.C WC US/CA

**80 893 65 - 01**

This document must not be copied without our written permission, and the contents thereof must not be imparted to a third party nor be used for any unauthorized purpose. Contravention will be prosecuted.  
 Asko Appliance AB

# Wiring diagram WM70.C US/CA

- WIRES IN ALL MACHINES
- · - · - WIRES IN SOME MACHINES
- - - - INTERNAL CONNECTION

- CABLE POSITIONS**
- 1: MOTOR COMMUNICATION
  - 2: THERMISTOR
  - 3: INLET VALVES
  - 4: DOOR LOCK, DRAIN PUMP, PREASSURE SWITCH
  - 6: COMMUNICATION INTERFACE
  - 7: COIN COLLECTOR
  - 8: POWER
  - 9: HEATING ELEMENT, PREASSURE SWITCH
  - 10: MOTOR POWER

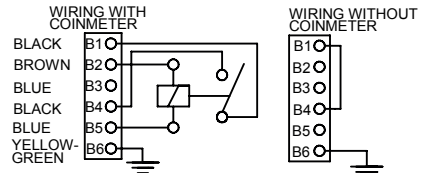
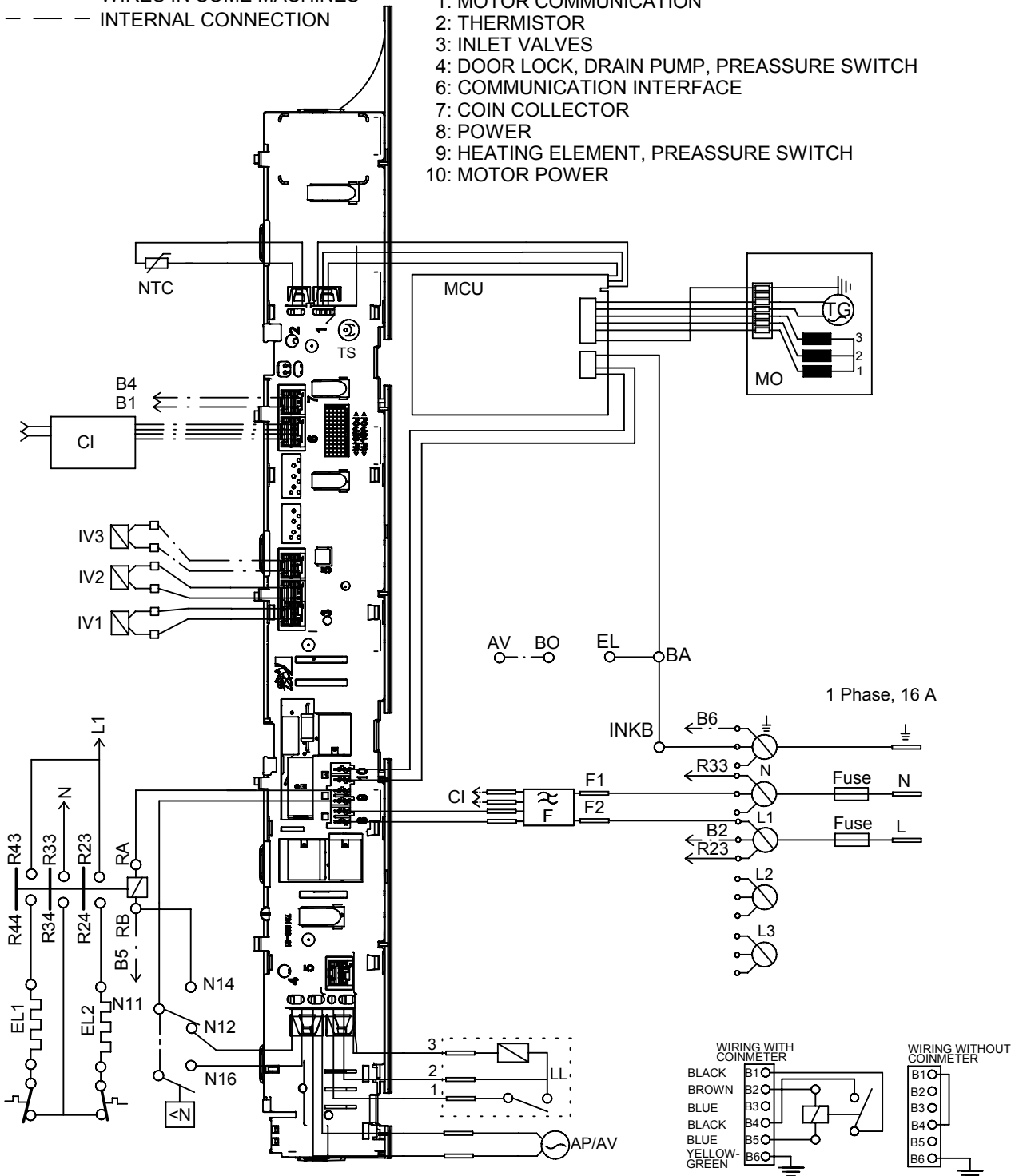

RESISTANCES AT ROOM TEMPERATURE (CA. 20°C/68°F)  
 VALUES WITHIN +/-10% ARE REGARDED AS NORMAL COMPONENT

F: RADIO INTERFERENCE SUPPRESSION FILTER	680K Ohm	
EL1: HEATING ELEMENT	25 Ohm	
EL2: HEATING ELEMENT	52 Ohm	
AP: DRAIN PUMP 60 Hz	76 Ohm	
AV: DRAIN VALVE	110 Ohm	
LL: DOOR LOCK, 1-2	122 Ohm	
NTC: THERMISTOR	6.1 - 3.8 K Ohm	
IV 1: INLET VALVE 1	3.7 K Ohm	
IV 2: INLET VALVE 2	3.7 K Ohm	
IV3: INLET VALVE 3	3.5 K Ohm	
MO: MOTOR, 1-3	4,3±7% Ohm	
1-2	4,3±7% Ohm	
2-3	4,3±7% Ohm	
MCU: MOTOR CONTROL UNIT		
N: PRESSURE SWITCH		<b><u>USER SETTINGS MENU</u></b>
TS: PRESSURE SENSOR		TURN OFF POWER (S1)
TG: TACHO GENERATOR		WAIT FOR AT LEAST 5 SEC
BA: CONTAINER		HOLD S5
INKB: INCOMING GROUND		TURN ON POWER (S1)
CI: COMMUNICATIONS INTERFACE		PRESS S5 5 TIMES TO ENTER MENU

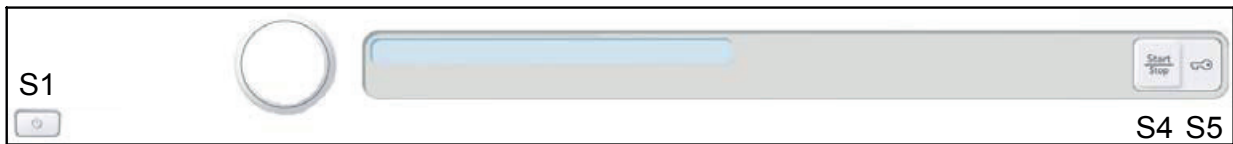

**SERVICE MENU**

TURN OFF POWER (S1)  
 WAIT FOR AT LEAST 5 SEC  
 HOLD S4  
 TURN ON POWER (S1)  
 PRESS S4 5 TIMES TO ENTER SERVICE MENU

PRESS DOOR OPENING (S5) TO CHANGE MENU STEP  
 ROTATE DIAL TO CHANGE IN STEP  
 PRESSING START/STOP (S4) STORES AND EXITS SERVICE MENU

**2010-05-20**

CIRCUIT DIAGRAM WM70.C US/CA

**80 896 25 - 00**

This document must not be copied without our written permission, and the contents thereof must not be imparted to a third party nor be used for any unauthorized purpose. Contravention will be prosecuted.  
 Asko Appliance AB

### Wiring diagram WM70.C 440V

- WIRES IN ALL MACHINES
- · - WIRES IN SOME MACHINES
- - - INTERNAL CONNECTION

**CABLE POSITIONS**

- 1: MOTOR COMMUNICATION
- 2: THERMISTOR
- 3: INLET VALVES
- 4: DOOR LOCK, DRAIN PUMP, PREASSURE SWITCH
- 6: COMMUNICATION INTERFACE
- 7: COIN COLLECTOR
- 8: POWER
- 9: HEATING ELEMENT, PREASSURE SWITCH
- 10: MOTOR POWER

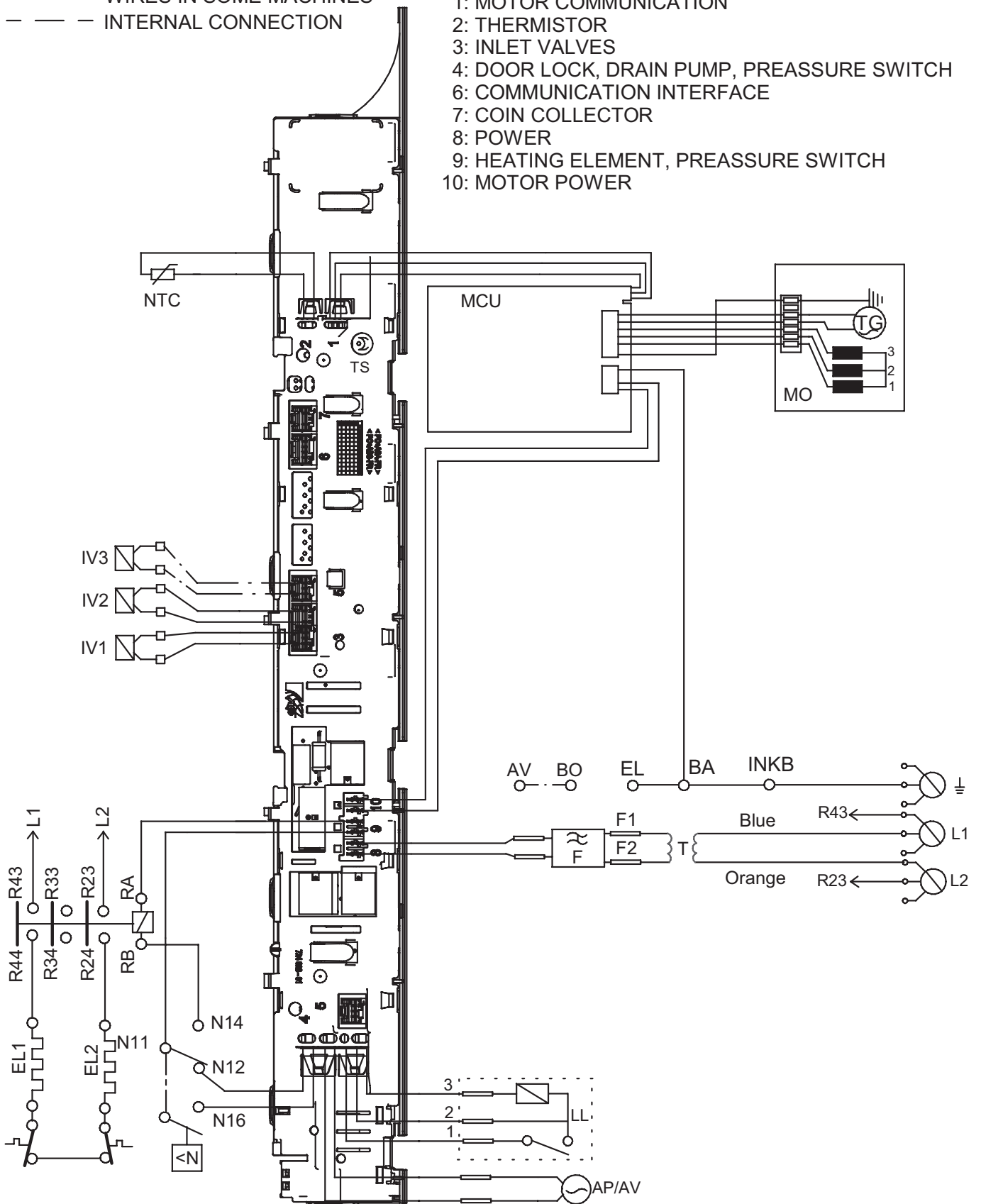

RESISTANCES AT ROOM TEMPERATURE (CA. 20°C/68°F)  
 VALUES WITHIN +/-10% ARE REGARDED AS NORMAL COMPONENT

F: RADIO INTERFERENCE SUPPRESSION FILTER	680K Ohm
EL1: HEATING ELEMENT	25 Ohm
EL2: HEATING ELEMENT	52 Ohm
AP: DRAIN PUMP 60 Hz	76 Ohm
AV: DRAIN VALVE	110/134 Ohm
LL: DOOR LOCK, 1-2	122 Ohm
NTC: THERMISTOR	6.1 - 3.8 K Ohm
IV 1: INLET VALVE 1	3.7 K Ohm
IV 2: INLET VALVE 2	3.7 K Ohm
IV3: INLET VLAVE 3	3.5 K Ohm
MO: MOTOR, 1-3	4,3±7% Ohm
1-2	4,3±7% Ohm
2-3	4,3±7% Ohm
MCU: MOTOR CONTROL UNIT	
N: PRESSURE SWITCH	
TS: PRESSURE SENSOR	
TG: TACHO GENERATOR	
BA: CONTAINER	
INKB: INCOMING GROUND	
T: TRANSFORMER	



**SERVICE MENU**

TURN OFF POWER (S1)  
 WAIT FOR AT LEAST 5 SEC  
 HOLD S4  
 TURN ON POWER (S1)  
 PRESS S4 5 TIMES TO ENTER SERVICE MENU

PRESS DOOR OPENING (S5) TO CHANGE MENU STEP  
 ROTATE DIAL TO CHANGE IN STEP  
 PRESSING START/STOP (S4) STORES AND EXITS SERVICE MENU

**USER SETTINGS MENU**

TURN OFF POWER (S1)  
 WAIT FOR AT LEAST 5 SEC  
 HOLD S5  
 TURN ON POWER (S1)  
 PRESS S5 5 TIMES TO ENTER MENU

**2012-09-10**

CIRCUIT DIAGRAM WM70.C MARINE

**80 896 27 - 01**

This document must not be copied without our written permission, and the contents thereof must not be imparted to a third party nor be used for any unauthorized purpose. Contravention will be prosecuted.  
 Asko Appliance AB

# Wiring diagram WM70.C HWC

\_\_\_\_\_ WIRES IN ALL MACHINES  
 - - - - - WIRES IN SOME MACHINES  
 - - - - - INTERNAL CONNECTION

## CABLE POSITIONS

- 1: MOTOR COMMUNICATION
- 2: THERMISTOR
- 3: INLET VALVES
- 4: DOOR LOCK, DRAIN PUMP, PREASSURE SWITCH
- 6: COMMUNICATION INTERFACE
- 7: COIN COLLECTOR
- 8: POWER
- 9: HEATING ELEMENT, PREASSURE SWITCH
- 10: MOTOR POWER

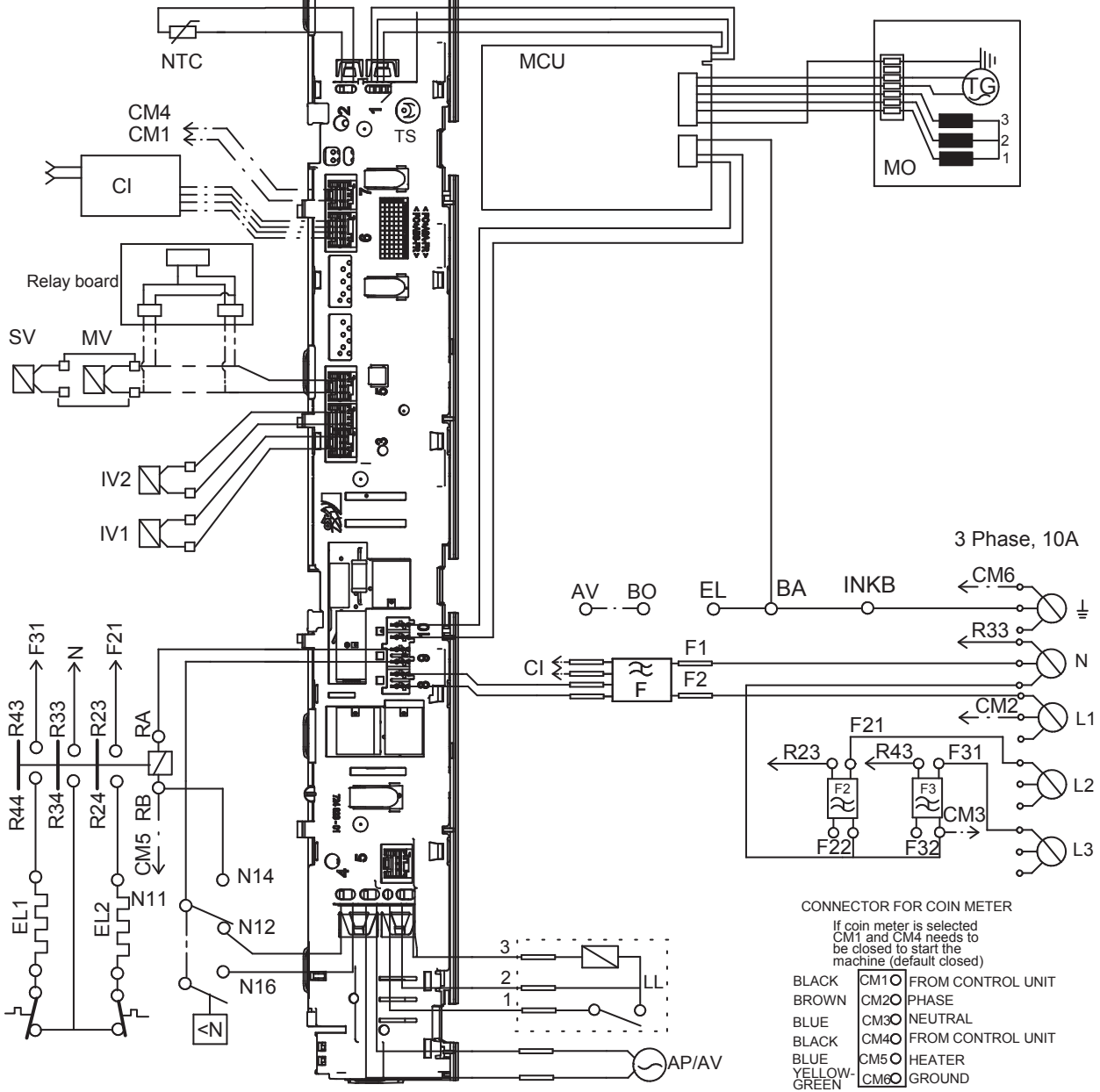

**CONNECTOR FOR COIN METER**  
 If coin meter is selected  
 CM1 and CM4 needs to  
 be closed to start the  
 machine (default closed)

BLACK	CM1	FROM CONTROL UNIT
BROWN	CM2	PHASE
BLUE	CM3	NEUTRAL
BLACK	CM4	FROM CONTROL UNIT
BLUE	CM5	HEATER
YELLOW-GREEN	CM6	GROUND

RESISTANCES AT ROOM TEMPERATURE (CA. 20°C/68°F)  
 VALUES WITHIN +/-10% ARE REGARDED AS NORMAL COMPONENT

F: RADIO INTERFERENCE SUPPRESSION FILTER	680K Ohm
EL: HEATING ELEMENT	25 Ohm
AP: DRAIN PUMP 50 Hz	144 Ohm
AP: DRAIN PUMP 60 Hz	76 Ohm
AV: DRAIN VALVE	110/134 Ohm
LL: DOOR LOCK, 1-2	122 Ohm
NTC: THERMISTOR	6.1 - 3.8 K Ohm
IV 1: INLET VALVE 1	3.7 K Ohm
IV 2: INLET VALVE 2	3.7 K Ohm
IV3: INLET VLAVE 3	3.5 K Ohm
MO: MOTOR, 1-3	4,3±7% Ohm
1-2	4,3±7% Ohm
2-3	4,3±7% Ohm
MCU: MOTOR CONTROL UNIT	
N: PRESSURE SWITCH	
TS: PRESSURE SENSOR	
TG: TACHO GENERATOR	
BA: CONTAINER	
INKB: INCOMING GROUND	
CI: COMMUNICATIONS INTERFACE	
MV: MAGNETIC VALVE	
SV: SWITCHING VALVE	

**USER SETTINGS MENU**

- TURN OFF POWER (S1)
- WAIT FOR AT LEAST 5 SEC
- HOLD S5
- TURN ON POWER (S1)
- PRESS S5 5 TIMES TO ENTER MENU



**SERVICE MENU**

- TURN OFF POWER (S1)
- WAIT FOR AT LEAST 5 SEC
- HOLD S4
- TURN ON POWER (S1)
- PRESS S4 5 TIMES TO ENTER SERVICE MENU

- PRESS DOOR OPENING (S5) TO CHANGE MENU STEP
- ROTATE DIAL TO CHANGE IN STEP
- PRESSING START/STOP (S4) STORES AND EXITS SERVICE MENU

1 Phase, 16 A

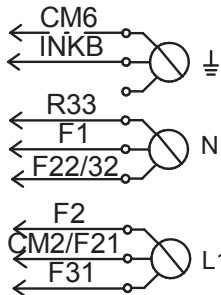

1 Phase, 10 A

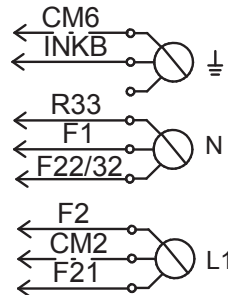

2011-11-11

CIRCUIT DIAGRAM WM70.C HWC

80 931 37 - 00

This document must not be copied without our written permission, and the contents thereof must not be imparted to a third party nor be used for any unauthorized purpose. Contravention will be prosecuted. Asko Appliance AB

## Panel and control card replacement

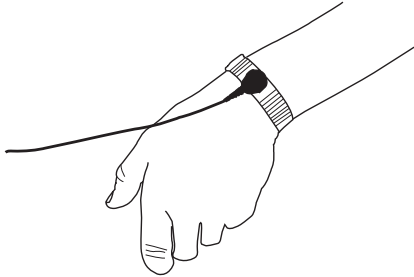
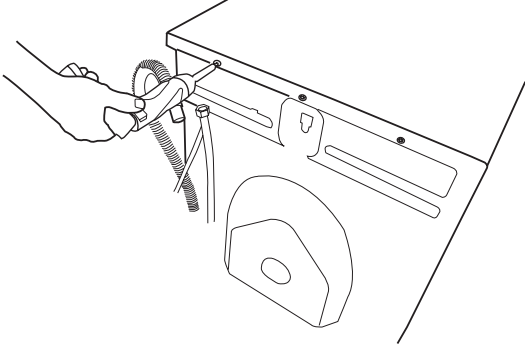
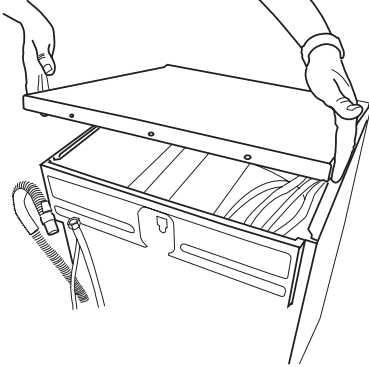
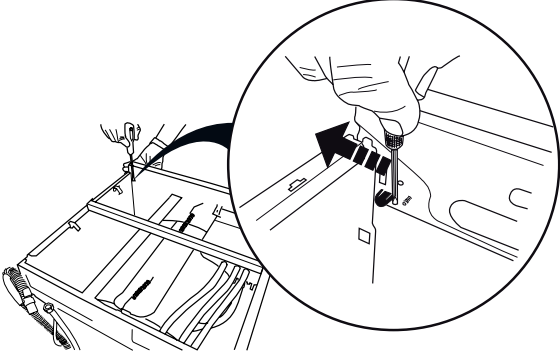
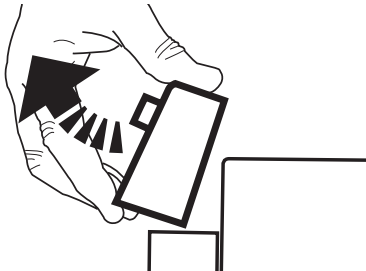
<p>1. Attach the anti-static wristband to a part of the machine that is earthed!</p> <p>NB: An anti-static wristband must be used, otherwise you risk destroying the control card.</p>	
<p>2. Undo the three screws holding the top cover in place.</p>	
<p>3. Remove the top cover.</p>	
<p>4. Use a screwdriver to carefully free the panel. As you do so, carefully angle the panel outwards.</p>	
<p>5. Remove the panel and the cables. NB: Don't forget to remove the pressure sensor tube.</p>	

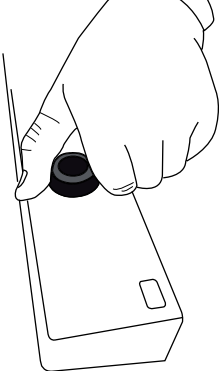
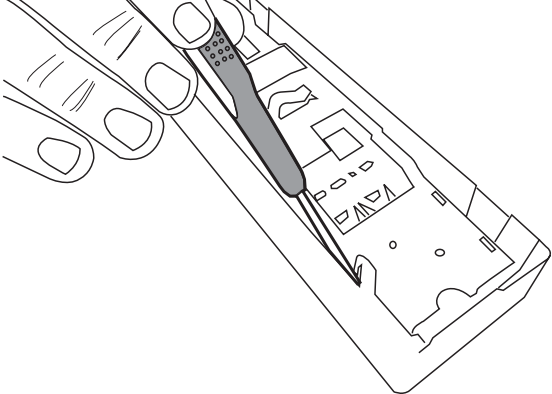
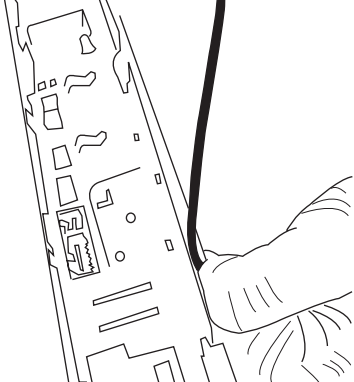

## Panel and control card replacement (cont.)

<p>6. Carefully pull the programme selector from the panel.</p>	
<p>7. Use a screwdriver to free the control card from the panel. NB: The control card must be placed in an ESD-safe bag.</p>	
<p>8. Check that the push button, lens and decorative inlay are in place. Now carefully press the new control card into place. NB: Don't forget to replace the rubber seal.</p>	

## Wash agitator removal

When replacing or cleaning the wash agitators, or when removing items that have fallen through the wash drum, first you need to remove the agitators. Follow the instructions below.

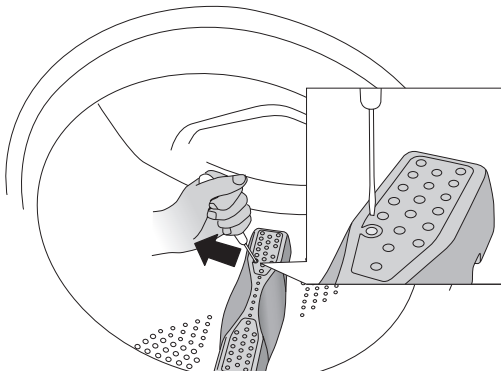
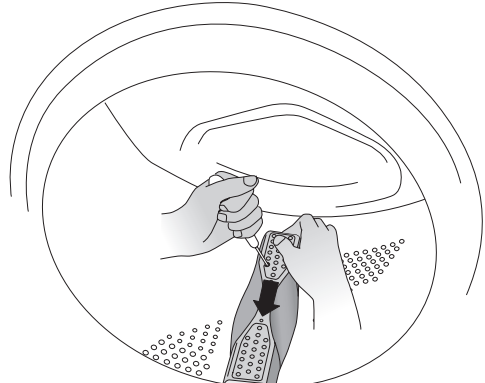
<p>1. Insert a screwdriver or the like into the hole on the agitator as illustrated and carefully pry to the left.</p>	
<p>2. Use your other hand to grasp the agitator and pull it towards you. 3. Lift the agitator. 4. Remove any foreign objects.</p>	
<p>5. Place the agitator in the mounting hole with the letter F towards you. Ensure that all the agitator fasteners are in their holes in the drum. Push it away from you until it fastens.</p>	