



**7 cft, No Frost, Top Mount
Refrigerator-Freezer
User Manual**

Models:

FF821W | FF882PL | LFF823W | LFF835PL

**BEFORE USE, PLEASE READ AND FOLLOW ALL SAFETY RULES AND
OPERATING INSTRUCTIONS.**

Models:

Serial Number:

Felix Storch, Inc.
An ISO 9001:2015 registered company
770 Garrison Ave
Bronx, New York 10474
www.summitappliance.com

Table of Contents

Safety Information.....	1-4
Overview	5
Reversing the Door Swing.....	6-8
Installation	9-10
Daily Use.....	11-13
Troubleshooting.....	15
Limited Warranty.....	17

Safety information

In the interest of your safety and to ensure the correct usage, before installing and first using the appliance, read this user manual carefully, including its tips and warnings. To avoid any unnecessary mistakes and accidents, it is important to ensure that all people using the appliance are thoroughly familiar with its operation and safety features. Save these instructions and make sure that they remain with the appliance if it is moved or sold, so that everyone using it throughout its life will be properly informed on the appliance's use and safety. Please follow the precautions detailed in this user manual, as the manufacturer is not responsible for damages caused by not doing so.

Children and Vulnerable People's Safety

- This appliance can be used by children aged 8 years and above. Persons with reduced physical, sensory, or mental capabilities or lack of experience can operate it if they are being supervised or instructed on how to use the appliance by a person responsible for their safety.
- Children should be supervised to ensure that they do not play with the appliance.
- Cleaning and user maintenance shall not be done by children unless they are of age 8 and above and are supervised.
- Keep all packaging away from children, they are at risk of suffocation.
- If you are discarding the appliance, pull the plug out of the socket, cut the cord (as close to the appliance as possible), and remove the door to prevent children from suffocating, being electrocuted, or locking themselves in it.
- If this appliance features a magnetic door seal to replace an older appliance having a spring lock (latch) on the door or lid, make sure to make that spring lock unusable before you discard the old appliance. This will prevent it from becoming a death trap for a child.

General Safety

 **WARNING!** Keep ventilation openings, in the appliance's enclosure or in the built-in structure, clear of obstruction.

 **WARNING!** Do not use mechanical devices or other methods to accelerate the defrosting process, other than those recommended by the manufacturer.

 **WARNING!** Do not damage the refrigerant circuit.



Safety information

⚠ WARNING! Do not use other electrical appliances (such as ice cream makers) inside refrigerating appliances unless they are approved by the manufacturer.

- Do not store explosive substances such as aerosol cans with a flammable propellant in this appliance.
- The refrigerant isobutane (R600a) is contained within the refrigerant circuit of the appliance, a natural gas with a high level of environmental compatibility, which is flammable.
- During transportation and installation of the appliance, make sure that none of the components of the refrigerant circuit become damaged.
 - avoid open flames and sources of ignition
 - thoroughly ventilate the room in which the appliance is situated
- It is dangerous to alter the specifications or modify this product in any way. Any damage to the cord may cause a short circuit, fire, and/or electric shock.
- This appliance is intended to be used in household and similar applications such as
 - staff kitchen areas in shops, offices, and other working environments.
 - Farmhouses and clients in hotels, motels, and other types of residential environments.
 - bed and breakfast type of environments.
 - catering and similar non-retail applications.

⚠ WARNING! Any electrical components (plug, power cord, compressor, etc.) must be replaced by a certified service agent or qualified service personnel.

- Power cord must not be lengthened.
- Make sure that the power plug is not squashed or damaged by the back of the appliance. A squashed or damaged power plug may overheat and cause a fire.
- Make sure that you can reach the main plug of the appliance.
- Do not pull the main cable.
- If the power plug socket is loose, do not insert the power plug. There is a risk of electric shock or fire.
- You must not operate the appliance if the lamp inside the refrigerator does not turn on.
- This appliance is heavy. Care should be taken when moving it.
- Do not remove nor touch items from the freezer compartment if your hands are damp/wet, as this could cause skin abrasions or frost/freezer burns.
- Avoid prolonged exposure of the appliance to direct sunlight.



Safety information

Daily use

- Do not put anything hot on the plastic parts of the appliance.
- Do not place food products directly against the rear wall.
- Frozen food must not be re-frozen once it has been thawed out.
- Store pre-packed frozen food in accordance with the frozen food manufacture-s instructions.¹
- The appliance's manufacturer's storage recommendations should be strictly adhered to. Refer to relevant instructions.
- Do not place carbonated or fizzy drinks in the freezer compartment as it creates pressure on the container, which may cause it to explode, resulting in damage to the appliance.¹
- Ice cubes can cause frost burns if consumed straight from the appliance.¹

Care and cleaning

- Before maintenance, switch off the appliance and disconnect the main plug from the main socket.
- Do not clean the appliance with metal objects.
- Do not use sharp objects to remove frost from the appliance. Use a plastic scraper.¹
- Regularly examine the drain in the refrigerator for defrosted water. If necessary, clean the drain. If the drain is blocked, water will collect at the bottom of the appliance.²

Installation

Important! For electrical connection carefully follow the instructions given in specific paragraphs.

- Unpack the appliance and check if there are damages to it. Do not connect the appliance if it is damaged. Report damages immediately to the place you bought it. In that case, retain packing.
- It is advisable to wait at least four hours before connecting the appliance to allow the refrigerant to flow back into the compressor.
- Adequate air circulation should be around the appliance, lacking this leads to overheating. To achieve sufficient ventilation, follow the instructions relevant to installation.
- Wherever possible the spacers of the product should be against a wall to avoid touching warm parts (compressor, condenser to prevent burns).
- The appliance must not be located close to radiators or cookers.
- Make sure that the main plug is accessible after the installation of the appliance.

1) If there is a freezer compartment.

2) If there is a fresh-food storage compartment.



Safety information

Service

- Any electrical work required to do with servicing of the appliance should be carried out by a qualified electrician or competent person.
- This product must be serviced by an Authorized Service Center, and only genuine spare parts must be used.

Energy saving

- Do not put hot food in the appliance.
- Do not pack food close together as this prevents air circulation.
- Make sure food does not touch the back of the compartment(s).
- If the electricity goes off, do not open the door(s).
- Do not open the door(s) frequently.
- Do not keep the door(s) open for too long a time.
- Do not set the thermostat to exceedingly cold temperatures.
- Some accessories, such as drawers, can be removed to get a larger storage volume and lower energy consumption.

Environment Protection

 This appliance does not contain gasses that could damage the ozone layer, in either its refrigerant circuit or insulation materials. The appliance shall not be discarded together with the urban refuse and rubbish. The insulation foam contains flammable gases: the appliance shall be disposed of according to the appliance regulations as obtained from your local authorities. Avoid damaging the cooling unit, especially the heat exchanger. The materials used in this appliance marked by the symbol ♻ are recyclable.

The symbol  on the product or on its packaging indicates that this product may not be treated as household waste. Instead, it should be taken to the appropriate collection point for the recycling of electrical and electronic equipment. By ensuring this product is disposed of correctly, you will help prevent potential negative consequences for the environment and human health, which could otherwise be caused by inappropriate waste handling of this product. For more detailed information about recycling this product, please contact your local council, your household waste disposal service, or, the shop where you purchased the product.

Packaging materials

The materials with the symbol ♻ are recyclable. Dispose of the packaging in suitable collection containers to recycle it.

Disposal of the appliance

1. Disconnect the main plug from the main socket.
2. Cut off the main cable and discard it.

Overview

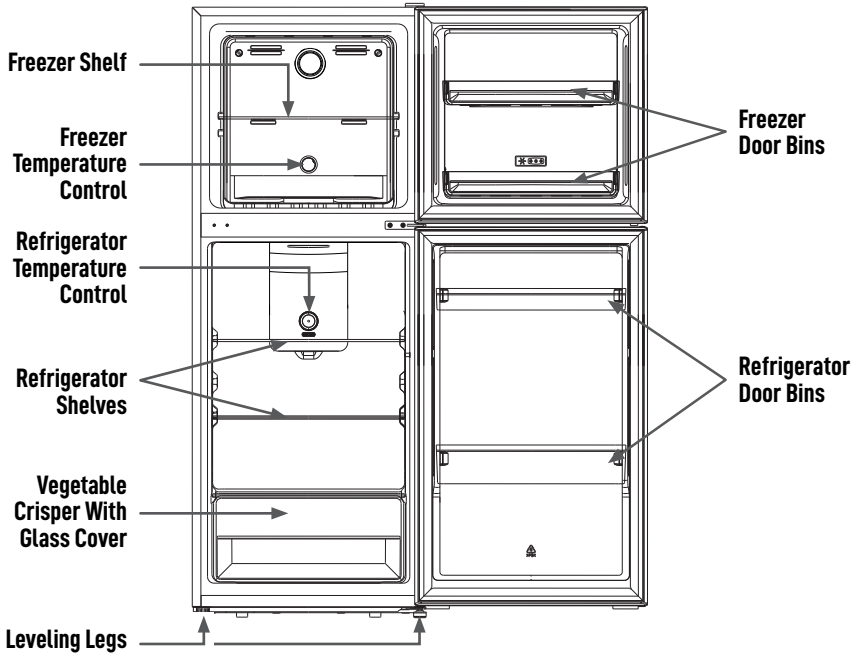

Note: Above picture is for reference only. The actual appliance may be slightly different.

Reversing the Door Swing

Before reversing the door, please be prepared below tools and material: straight screwdriver, cross screwdriver, spanner and the components included in the poly bag:

Left hinger x1 Left hinge cover x1 Left middle stopper x1 Left middle stopper metal block x1



1. Close upper door, take out the screw from the top hinge covers by cross screwdriver. Take off hinge cover, then unscrew top hinge and take off upper door.

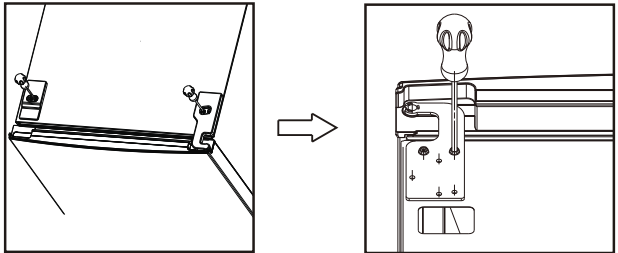

2. Unscrew from the middle hinge by cross screwdriver, then take off the lower door.

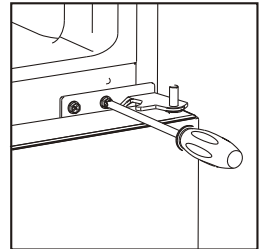

3. Laying down the refrigerator, take out the adjusting feet as below, then unscrew the lower hinge by cross screwdriver.

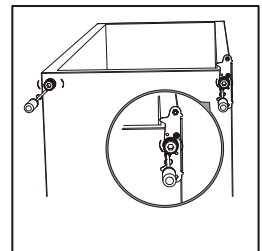

Reversing the Door Swing

4 . Unscrew and remove the bottom hinge pin, turn the bracket over and replace it.

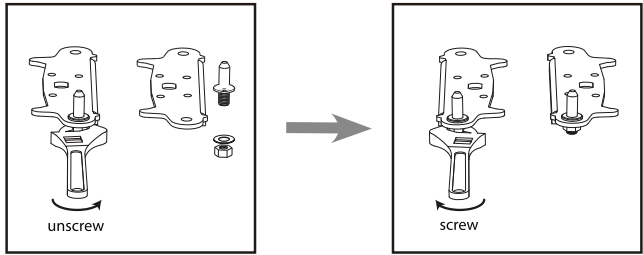

5. Refit the bracket fitting the bottom hinge pin. Replace both adjustable feet. Transfer the lower door to the property position.

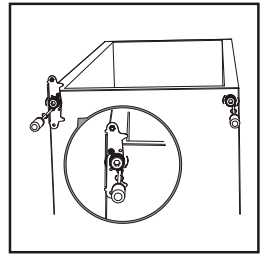

6. Make the middle hinge reverse the direction 180°C, then transfer it to the left property position. Make the middle hinge pin in the upper hole of the lower door, then tight the screws.

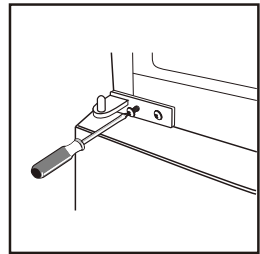

7. Unscrew right middle stopper with metal block from bottom of upper door. And then install left middle stopper and metal block in left side of bottom of upper door.

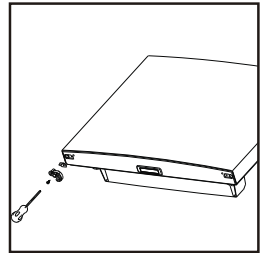
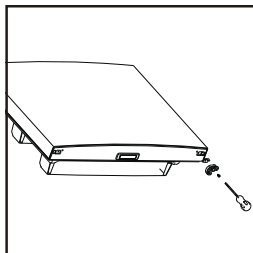

Reversing the Door Swing

8. Install the upper door, fix the upper door hinge onto the cabinet .

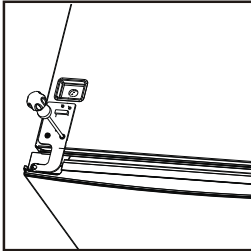

9. Take left hinge cover from accessory bag and install it with top hinge. Then install hole cover at right side.

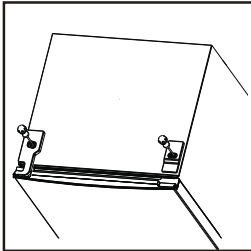

10. Detach the Fridge and the Freezer door gaskets and then attach them after rotating.

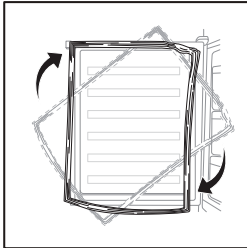

Installation

Space Requirement

- Select a location without direct exposure to sunlight, enough space for the refrigerator doors to open easily, and with level (or nearly level) flooring.
- Allow sufficient space to install the refrigerator on a flat surface.
- Allow clearance to the right, left, back, and top when installing. This will help reduce power consumption and keep your energy bills lower.

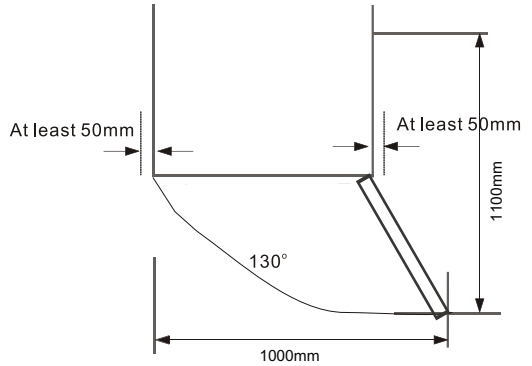
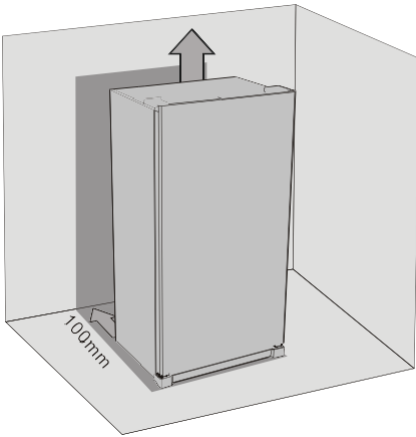

Leveling the unit

To do this adjust the two leveling feet at front of the unit.

If the unit is not level, the doors and magnetic seal alignments will not be covered properly.

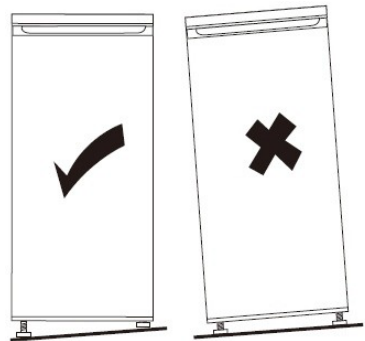

Installation

Positioning

Install this appliance at a location where the ambient temperature corresponds to the climate class indicated on the rating plate of the appliance:

Climate class	Ambient temperature
SN	50°F to 86°F
N	60.8°F to 89.6°F
ST	60.8°F to 100.4°F
T	60.8°F to 109.4°F

Location

The appliance should be installed well away from sources of heat such as radiators, boilers, direct sunlight, etc. Ensure that air can circulate freely around the back of the cabinet. To ensure the best performance, if the appliance is positioned below an overhanging wall unit, the minimum distance between the top of the cabinet and the wall must be at least 4 inches. However, ideally, the appliance should not be positioned below the overhanging wall unit. Accurate leveling is ensured by one or more adjustable feet at the base of the cabinet.



Warning! It must be possible to disconnect the appliance from the main power supply; the plug must be easily accessible after installation.

Daily Use

Freezer Compartment Temperature Setting

- The freezer's internal temperature is controlled by a sensor with 3 settings: SUMMER, RECOMMENDED/NORMAL, and WINTER.
- The freezer may not operate at the correct temperature if the room is too hot or if you open the door frequently.

Important!

We recommend setting the temperature control knob to **"NORMAL"** or **"RECOMMENDED"** for regular use.

- Set the knob to **"SUMMER"** during summer or hot days.
- If the ambient temperature is very high (above 43°C / 109°F), adjust the knob to the dotted line on the left.
- Set the knob to **"WINTER"** during winter or cold days .
- If the ambient temperature is very low (below 10°C / 50°F), adjust the knob to the dotted line on the right.

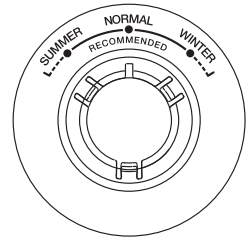

After plugging in your appliance, the internal temperature is regulated by a built-in sensor. The temperature control has 8 settings: 0, 1, 2, 3, 4, 5, 6, and 7.

- 0: The appliance is turned off.
- 1: The warmest setting.
- 7: The coldest setting.

Note: The appliance may not maintain the correct temperature in extremely hot environments or if the door is opened frequently. Additionally, both the fridge and freezer compartments will stop functioning when the temperature control is set to OFF (0).

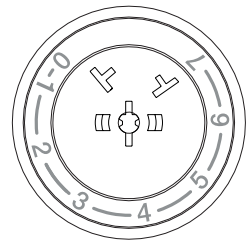

WE DO NOT RECOMMEND THE INSTALLATION OF THE REFRIGERATOR WHERE THE TEMPERATURE WILL DROP BELOW 50°F (13°C) OR RISE ABOVE 110°F (43°C). THE COMPRESSOR WILL NOT BE ABLE TO MAINTAIN PROPER TEMPERATURES INSIDE THE REFRIGERATOR.

FOR INSTALLATIONS WHERE THE TEMPERATURES WILL DROP BELOW 50° SET THE FREEZER TEMPERATURE CONTROL TO THE "COLDEST" SETTING. THIS WILL IMPROVE THE OPERATIONS OF THE REFRIGERATOR UNDER THESE CONDITIONS.

Daily Use

First use

Cleaning the interior

Before using the appliance for the first time, wash the interior and all internal accessories with lukewarm water and some neutral soap so as to remove the typical smell of a brand new product, then dry thoroughly.

Important! Do not use detergents or abrasive powders, as these will damage the finish.

Daily use

Position different food in different compartments according to be below table

Refrigerator compartments	Type of food
Door or balconies of fridge compartment	<ul style="list-style-type: none">• Foods with natural preservatives, such as jams, juices, drinks, condiments.• Do not store perishable foods.
Crisper drawer (salad drawer)	<ul style="list-style-type: none">• Fruits, herbs and vegetables should be placed separately in the crisper bin.• Do not store bananas, onions, potatoes, garlic in the refrigerator.
Fridge shelf – middle	<ul style="list-style-type: none">• Dairy products, eggs
Fridge shelf – top	<ul style="list-style-type: none">• Foods that do not need cooking, such as ready-to-eat foods, deli meats, leftovers.
Freezer drawer(s)/shelf	<ul style="list-style-type: none">• Foods for long-term storage.• Bottom drawer/shelf for raw meat, poultry, fish.• Middle drawer/shelf for frozen vegetables, chips.• Top drawer/shelf for ice cream, frozen fruit, frozen baked goods.

Freezing fresh food

- The freezer compartment is suitable for freezing fresh food and storing frozen and deep-frozen food for a long time.
- Place the fresh food to be frozen in the bottom compartment.
- The maximum amount of food that can be frozen in 24 hours is specified on the rating plate.
- The freezing process lasts 24 hours: during this period do not add other food to be frozen.

Storing frozen food

When first starting-up or after a period out of use, before putting the product in the compartment let the appliance run at least 2 hours on the higher settings.

Important! In the event of accidental defrosting, for example the power has been off for longer than the value shown in the technical characteristics chart under "rising time", the defrosted food must be consumed quickly or cooked immediately and then re-frozen (after cooked).

Daily Use

Thawing

Deep-frozen or frozen food, prior to be used, can be thawed in the fridge compartment or at room temperature, depending on the time available for this operation.

Small pieces may even be cooked still frozen, directly from the freezer. In this case, cooking will take longer.

Accessories

Movable shelves

The walls of the refrigerator are equipped with a series of runners so that the shelves can be positioned as desired.

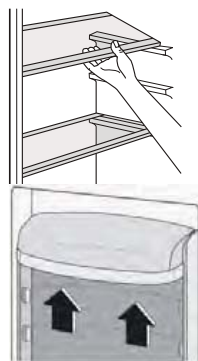

Positioning the door balconies

To permit storage of food packages of various sizes, the door balconies can be placed at different heights. To make these adjustments proceed as follows: gradually pull the balcony in the direction of the arrows until it comes free, then reposition as required.

Helpful hints and tips

Hints for freezing

To help you make the most of the freezing process, here are some important hints:

- the maximum quantity of food which can be frozen in 24 hrs. is shown on the rating plate;
- the freezing process takes 24 hours. No further food to be frozen should be added during this period;
- only freeze top quality, fresh and thoroughly cleaned, foodstuffs;
- prepare food in small portions to enable it to be rapidly and completely frozen and to make it possible subsequently to thaw only the quantity required;
- wrap up the food in aluminium foil or polythene and make sure that the packages are airtight;
- do not allow fresh, unfrozen food to touch food which is already frozen, thus avoiding a rise in temperature of the latter;
- lean foods store better and longer than fatty ones; salt reduces the storage life of food;
- water ices, if consumed immediately after removal from the freezer compartment, can possibly cause the skin to be freeze burnt;
- it is advisable to show the freezing in date on each individual pack to enable you removal from the freezer compartment, can possibly cause the skin to be freeze burnt;
- it is advisable to show the freezing in date on each individual pack to enable you to keep track of the storage time.

Hints for storage of frozen food

To obtain the best performance from this appliance, you should:

make sure that the commercially frozen foodstuffs were adequately stored by the retailer;

be sure that frozen foodstuffs are transferred from the food store to the freezer in the shortest possible time;

not open the door frequently or leave it open longer than absolutely necessary.

Once defrosted, food deteriorates rapidly and cannot be refrozen.

Do not exceed the storage period indicated by the food manufacture.

Hints for fresh food refrigeration

To obtain the best performance:

- Do not store warm food or evaporating liquids in the refrigerator
- Do cover or wrap the food, particularly if it has a strong flavour

Hints for refrigeration

Useful hints:

- Make (all types): wrap in polythene bags and place on the glass shelves above the vegetable drawer.
- For safety, store in this way only one or two days at the most.
- Cooked foods, cold dishes, etc...: these should be covered and may be placed on any shelf.
- Fruit and vegetables: these should be thoroughly cleaned and placed in the special drawer(s) provided.
- butter and cheese: these should be placed in special airtight containers or wrapped in aluminum foil or polythene bags to exclude as much air as possible.
- Milk bottle: these should have a cap and should be stored in the balconies on the door.
- Bananas, potatoes, onions and garlic, if not packed, must not be kept in the fridge.

Daily Use

Cleaning

For hygienic reasons the appliance interior, including interior accessories, should be cleaned regularly.

 **Caution!** The appliance may not be connected to the mains during cleaning. Danger of electrical shock! Before cleaning switch the appliance off and remove the plug from the mains, or switch off or turn out the circuit breaker or fuse. Never clean the appliance with a steam cleaner. Moisture could accumulate in electrical components, danger of electrical shock! Hot vapors can lead to the damage of plastic parts. The appliance must be dry before it is placed back into service.

Important! Ethereal oils and organic solvents can attack plastic parts, e.g. lemon juice or the juice from orange peel, butyric acid, cleanser that contain acetic acid.

- Do not allow such substances to come into contact the appliance parts.
- Do not use any abrasive cleaners
- Remove the food from the freezer. Store them in a cool place, well covered.
- Switch the appliance off and remove the plug from the mains, or switch off or turn out the circuit breaker of fuse.
- Clean the appliance and the interior accessories with a cloth and lukewarm water. After cleaning wipe with fresh water and rub dry.
- After everything is dry place appliance back into service.

Troubleshooting

⚠ Caution! Before troubleshooting, disconnect the power supply. Only a qualified electrician or competent person must do the troubleshooting that is not in this manual.

Important! There will be some sound/noise during normal operation (compressor or refrigerant circulation).

Problem	Possible cause	Solution
Appliance does not work	Mains plug is not plugged in or is loose	Insert mains plug.
	Fuse has blown or is defective	Check fuse, replace if necessary.
	Socket is defective	Mains malfunctions are to be corrected by an electrician.
Appliance freezes or cools too much	Temperature is set too cold	Turn the temperature regulator to a warmer setting temporarily.
The food is not frozen enough.	Temperature is not properly adjusted.	Please look in the initial Temperature Setting section.
	Door was open for an extended period.	Open the door only as long as necessary.
	A large quantity of warm food was placed in the appliance within the last 24 hours.	Turn the temperature regulation to a colder setting temporarily.
	The appliance is near a heat source.	Please look in the installation location section.
Heavy build up of frost on the door seal.	Door seal is not air tight.	Carefully warm the leaking sections of the door seal with a hair dryer (on a cool setting). At the same time shape the warmed door seal by hand such that it sits correctly.
Unusual noises	Appliance is not level.	Re-adjust the feet.
	The appliance is touching the wall or other objects.	Move the appliance slightly.
	A component, e.g. a pipe, on the rear of the appliance is touching another part of the appliance or the wall.	If necessary, carefully bend the component out of the way.

If you have checked the table and find that you still need help with your appliance, call our Customer Service facility at **800-932-4267 (Ext. 513)** between 9:00 AM and 5:00 PM ET or visit **summitappliance.com/support**. We will do our best to answer your questions.

To order replacement parts, visit our website: **summitapplianceparts.com**

NOTES

CALIFORNIA CARB/SNAP DISCLOSURE

This product uses eco-friendly hydrocarbon refrigerant and fully complies with California CARB regulations.

However, we are required by California Law to provide the following disclosure statement in every product sold in California.

"This equipment is prohibited from use in California with any refrigerants on the 'List of Prohibited Substances' for that specific end-use, in accordance with California Code of Regulations, title 17, section 95374. This disclosure statement has been reviewed and approved by Felix Storch, Inc. and Felix Storch, Inc. attests, under penalty of perjury, that these statements are true and accurate."

LIMITED WARRANTY

ONE-YEAR LIMITED WARRANTY

Warranty coverage is available within the 48 contiguous United States, along with select areas of Alaska, Hawaii, and Canada. For locations not covered, consumers can either contact a local provider or coordinate with Felix Storch, Inc. to find nearby service options, which may qualify for partial reimbursement.

The warranty for this appliance is valid for one year from the date of purchase, provided the appliance is operated and maintained according to the instructions included with the product. The warrantor will cover the cost of factory-specified parts and repair labor needed to correct defects in materials or workmanship. Service must be performed by a designated service company.

All parts, except the compressor, are warranted for one year against manufacturing defects. Plastic parts, shelves, and cabinets are produced to commercially acceptable standards but are not covered for damages incurred during handling or for breakage.

5-YEAR COMPRESSOR WARRANTY

1. The compressor is covered for 5 years.
2. Replacement does not include labor.

ITEMS WARRANTOR WILL NOT PAY FOR:

1. Service calls to correct the installation of your appliance, to instruct you how to use your appliance, to replace or repair fuses or to correct wiring or plumbing.
2. Service calls to repair or replace appliance light bulbs or broken shelves. Consumable parts (such as filters) are excluded from warranty coverage.
3. Damage resulting from accident, alteration, misuse, abuse, fire, flood, acts of God, improper installation, installation not in accordance with electrical or plumbing codes, or use of products not approved by warrantor.
4. Replacement parts or repair labor costs for units operated outside the 48 contiguous United States, along with select areas of Alaska, Hawaii, and Canada.
5. Repairs to parts or systems resulting from unauthorized modifications made to the appliance.
6. Expenses for travel and transportation for product service in remote locations.
7. The removal and reinstallation of your appliance if it is installed in an inaccessible location or is not installed in accordance with published installation instructions.

DISCLAIMER OF IMPLIED WARRANTIES; LIMITATION OF REMEDIES

CUSTOMER'S SOLE AND EXCLUSIVE REMEDY UNDER THIS LIMITED WARRANTY SHALL BE PRODUCT REPAIR AS PROVIDED HEREIN. IMPLIED WARRANTIES, INCLUDING WARRANTIES OF MERCHANTABILITY OR FITNESS FOR A PARTICULAR PURPOSE, ARE LIMITED TO ONE YEAR. WARRANTOR SHALL NOT BE LIABLE FOR INCIDENTAL OR CONSEQUENTIAL DAMAGES. SOME STATES DO NOT ALLOW THE EXCLUSION OR LIMITATION OF INCIDENTAL OR CONSEQUENTIAL DAMAGES, OR LIMITATIONS ON THE DURATION OF IMPLIED WARRANTIES OF MERCHANTABILITY OR FITNESS, SO THESE EXCLUSIONS OR LIMITATIONS MAY NOT APPLY TO YOU. THIS WARRANTY GIVES YOU SPECIFIC LEGAL RIGHTS AND YOU MAY ALSO HAVE OTHER RIGHTS, WHICH VARY FROM STATE TO STATE.



WARNING: This product can expose you to chemicals including Nickel (Metallic) which is known to the State of California to cause cancer.

For more information go to www.P65Warnings.ca.gov

Note: Nickel is a component in all stainless steel and some other metallic compositions.



Felix Storch, Inc.
An ISO 9001:2015 registered company
770 Garrison Ave
Bronx, New York 10474
www.summitappliance.com